

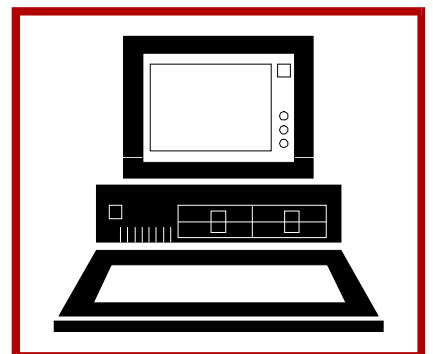

# Instruction

## Multi-Function Controller Termination Modules (NIMF01 and NIMF02)

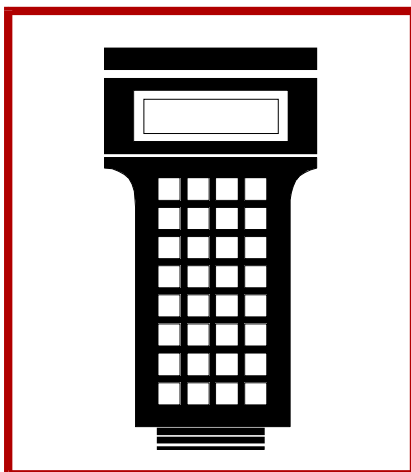
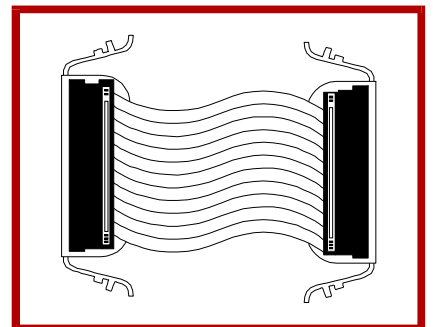
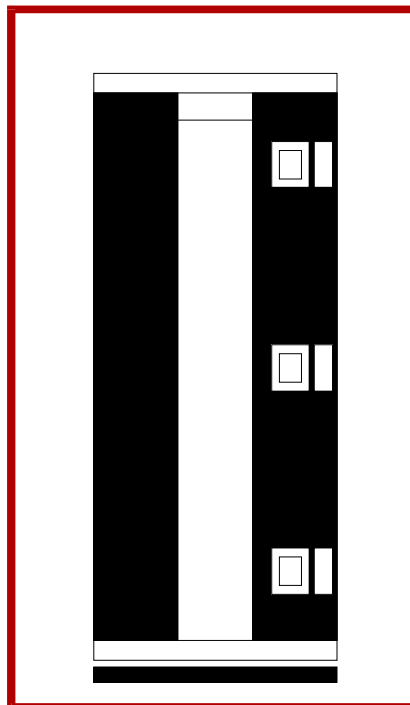
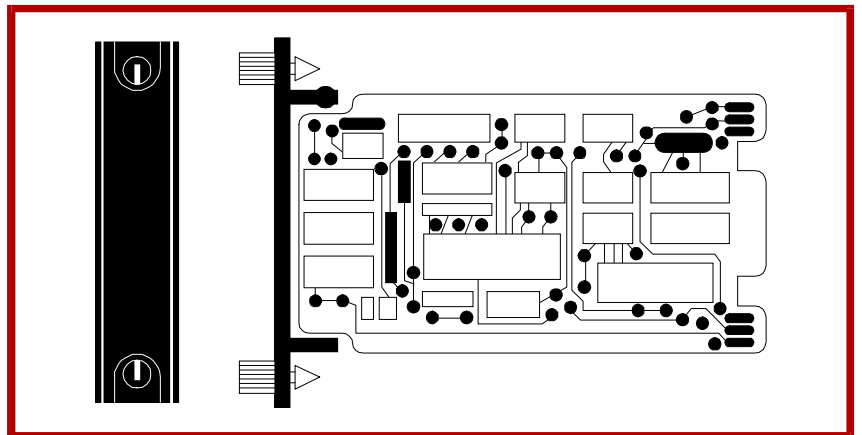
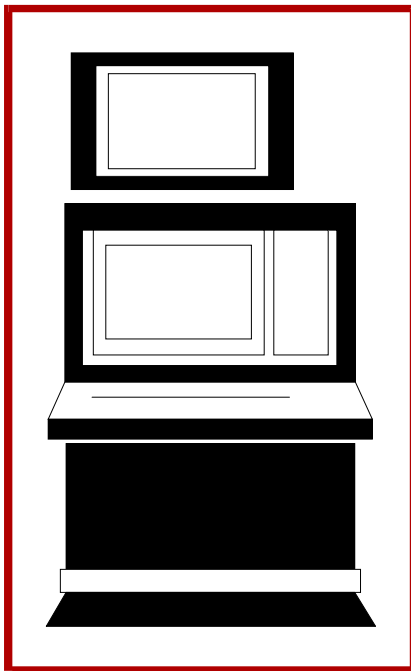

**WARNING** notices as used in this instruction apply to hazards or unsafe practices that could result in personal injury or death.

**CAUTION** notices apply to hazards or unsafe practices that could result in property damage.

**NOTES** highlight procedures and contain information that assists the operator in understanding the information contained in this instruction.

## WARNING

### INSTRUCTION MANUALS

DO NOT INSTALL, MAINTAIN, OR OPERATE THIS EQUIPMENT WITHOUT READING, UNDERSTANDING, AND FOLLOWING THE PROPER **Elsag Bailey** INSTRUCTIONS AND MANUALS; OTHERWISE, INJURY OR DAMAGE MAY RESULT.

### RADIO FREQUENCY INTERFERENCE

MOST ELECTRONIC EQUIPMENT IS INFLUENCED BY RADIO FREQUENCY INTERFERENCE (RFI). CAUTION SHOULD BE EXERCISED WITH REGARD TO THE USE OF PORTABLE COMMUNICATIONS EQUIPMENT IN THE AREA AROUND SUCH EQUIPMENT. PRUDENT PRACTICE DICTATES THAT SIGNS SHOULD BE POSTED IN THE VICINITY OF THE EQUIPMENT CAUTIONING AGAINST THE USE OF PORTABLE COMMUNICATIONS EQUIPMENT.

### POSSIBLE PROCESS UPSETS

MAINTENANCE MUST BE PERFORMED ONLY BY QUALIFIED PERSONNEL AND ONLY AFTER SECURING EQUIPMENT CONTROLLED BY THIS PRODUCT. ADJUSTING OR REMOVING THIS PRODUCT WHILE IT IS IN THE SYSTEM MAY UPSET THE PROCESS BEING CONTROLLED. SOME PROCESS UPSETS MAY CAUSE INJURY OR DAMAGE.

## AVERTISSEMENT

### MANUELS D'OPÉRATION

NE PAS METTRE EN PLACE, RÉPARER OU FAIRE FONCTIONNER L'ÉQUIPEMENT SANS AVOIR LU, COMPRIS ET SUIVI LES INSTRUCTIONS RÉGLEMENTAIRES DE **Elsag Bailey**. TOUTE NÉGLIGENCE À CET ÉGARD POURRAIT ÊTRE UNE CAUSE D'ACCIDENT OU DE DÉFAILLANCE DU MATÉRIEL.

### PERTURBATIONS PAR FRÉQUENCE RADIO

LA PLUPART DES ÉQUIPEMENTS ÉLECTRONIQUES SONT SENSIBLES AUX PERTURBATIONS PAR FRÉQUENCE RADIO. DES PRÉCAUTIONS DEVRONT ÊTRE PRISES LORS DE L'UTILISATION DU MATÉRIEL DE COMMUNICATION PORTATIF. LA PRUDENCE EXIGE QUE LES PRÉCAUTIONS À PRENDRE DANS CE CAS SOIENT SIGNALÉES AUX ENDROITS VOULUS DANS VOTRE USINE.

### PERTURBATIONS DU PROCÉDÉ

L'ENTRETIEN DOIT ÊTRE ASSURÉ PAR UNE PERSONNE QUALIFIÉE EN CONSIDÉRANT L'ASPECT SÉCURITAIRE DES ÉQUIPEMENTS CONTRÔLÉS PAR CE PRODUIT. L'AJUSTEMENT ET/OU L'EXTRACTION DE CE PRODUIT PEUT OCCASIONNER DES À-COUPS AU PROCÉDÉ CONTRÔLE LORSQU'IL EST INSÉRÉ DANS UNE SYSTÈME ACTIF. CES À-COUPS PEUVENT ÉGALEMENT OCCASIONNER DES BLESSURES OU DES DOMMAGES MATÉRIELS.

## NOTICE

The information contained in this document is subject to change without notice.

Elsag Bailey, its affiliates, employees, and agents, and the authors and contributors to this publication specifically disclaim all liabilities and warranties, express and implied (including warranties of merchantability and fitness for a particular purpose), for the accuracy, currency, completeness, and/or reliability of the information contained herein and/or for the fitness for any particular use and/or for the performance of any material and/or equipment selected in whole or part with the user of/or in reliance upon information contained herein. Selection of materials and/or equipment is at the sole risk of the user of this publication.

This document contains proprietary information of Elsag Bailey, Elsag Bailey Process Automation, and is issued in strict confidence. Its use, or reproduction for use, for the reverse engineering, development or manufacture of hardware or software described herein is prohibited. No part of this document may be photocopied or reproduced without the prior written consent of Elsag Bailey.

---

## Preface

---

Termination modules provide a connection from the plant equipment to the INFI 90<sup>®</sup> process modules. The NIMF01 Multi-Function Controller Termination Module terminates a multi-function controller, INFI-NET<sup>®</sup> to computer transfer module, Plant Loop to Plant Loop transfer module or Plant Loop to computer transfer module. The NIMF01 Multi-Function Controller Termination Module provides a termination point for two isolated RS-232-C ports plus a serial link to connect a control station through an NICS01 Control I/O Termination Module. The NIMF02 Multi-Function Controller Termination Module is used in addition to the NIMF01 termination module when terminating redundant modules. This product instruction explains how to install and use the NIMF01 and NIMF02 Multi-Function Controller Termination Modules.

## List of Effective Pages

---

Total number of pages in this manual is 51, consisting of the following:

<b>Page No.</b>	<b>Change Date</b>
Preface	Original
List of Effective Pages	Original
iii through vii	Original
1-1 through 1-7	Original
2-1 through 2-16	Original
3-1	Original
4-1 through 4-2	Original
5-1	Original
A-1 through A-3	Original
B-1 through B-2	Original
C-1 through C-2	Original
D-1 through D-3	Original
E-1 through E-3	Original
F-1 through F-3	Original
Index-1 through Index-2	Original

When an update is received, insert the latest changed pages and dispose of the superseded pages.

**NOTE:** On an updated page, the changed text or table is indicated by a vertical bar in the outer margin of the page at the changed area. A changed figure is indicated by a vertical bar in the outer margin next to the figure caption. The date the update was prepared will appear beside the page number.

---

## Safety Summary

---

**GENERAL  
WARNINGS****Equipment Environment**

All components, whether in transportation, operation or storage, must be in a noncorrosive environment.

**Electrical Shock Hazard During Maintenance**

Disconnect power or take precautions to insure that contact with energized parts is avoided when servicing.

**Special Handling**

This unit uses electrostatic sensitive devices.

**SPECIFIC  
CAUTIONS**

Remove a module from its assigned slot before installing or removing a cable assigned to that slot. Failure to do so could result in damage to the module. (p. 2-6)

It is strongly recommended that all power (cabinet, I/O, etc.) be turned off before doing any termination module wiring. Failure to do so could result in equipment damage. Do not apply power until all connections are verified. (p. 2-12, 4-1)

---

## Sommaire de Sécurité

---

**AVERTISSEMENTS  
D'ORDRE  
GÉNÉRAL**

**Environnement de l'équipement**

Ne pas soumettre les composants à une atmosphère corrosive lors du transport, de l'entreposage ou l'utilisation.

**Possibilité de chocs électriques durant l'entretien**

Débrancher l'alimentation ou prendre les précautions pour éviter tout contact avec des composants sous tension durant l'entretien.

**ATTENTIONS  
D'ORDRE  
SPÉCIFIQUE**

Avant de retirer ou de brancher un câble, retirez le module logé dans la coulisse correspondante. Autrement, le module risque d'être endommagé. (p. 2-6)

Il est fortement recommand, que toutes les alimentations (armoire, E/S, etc.) soient coupées avant d'effectuer quelque raccord que ce soit sur un carte de raccordement. Un manquement à ces instructions pourrait causer des dommage à l'équipement. Ne pas rebrancher les alimentations avant d'avoir vérifié tous les raccorde-ments. (p. 2-12, 4-1)

---

# Table of Contents

	<i>Page</i>
<b>SECTION 1 - INTRODUCTION</b> .....	<b>1-1</b>
OVERVIEW .....	1-1
INTENDED USER .....	1-2
MODULE DESCRIPTION .....	1-3
FEATURES .....	1-3
HARDWARE APPLICATION .....	1-4
INSTRUCTION CONTENT .....	1-4
HOW TO USE THIS MANUAL .....	1-4
GLOSSARY OF TERMS AND ABBREVIATIONS .....	1-4
REFERENCE DOCUMENTS .....	1-5
NOMENCLATURE .....	1-6
SPECIFICATIONS .....	1-6
<b>SECTION 2 - INSTALLATION</b> .....	<b>2-1</b>
INTRODUCTION .....	2-1
SPECIAL HANDLING .....	2-1
UNPACKING AND INSPECTION .....	2-2
SETUP/PHYSICAL INSTALLATION .....	2-2
Dipshunt Configuration for DTE or DCE .....	2-3
Dipshunt Configuration for a Mainframe Computer .....	2-3
Dipshunt Configuration for the INPPT01 Module .....	2-4
Sequence of Events Recorder .....	2-4
Cabling Connections .....	2-5
Cable Installation .....	2-6
NKTMO1 .....	2-7
NKTU02 OR NKTU12 .....	2-7
RS-232-C COMMUNICATION CABLE .....	2-9
RIBBON CABLE 6634408A2 .....	2-10
Installing the Termination Module .....	2-11
Terminal Wiring .....	2-12
<b>SECTION 3 - MAINTENANCE</b> .....	<b>3-1</b>
INTRODUCTION .....	3-1
MAINTENANCE SCHEDULE .....	3-1
<b>SECTION 4 - REPAIR/REPLACEMENT PROCEDURES</b> .....	<b>4-1</b>
INTRODUCTION .....	4-1
MODULE REPLACEMENT PROCEDURES .....	4-1
<b>SECTION 5 - SUPPORT SERVICES</b> .....	<b>5-1</b>
INTRODUCTION .....	5-1
REPLACEMENT PARTS AND ORDERING INFORMATION .....	5-1
TRAINING .....	5-1
TECHNICAL DOCUMENTATION .....	5-1
<b>APPENDIX A - IMMFC03 MULTI-FUNCTION CONTROLLER</b> .....	<b>A-1</b>
INTRODUCTION .....	A-1
<b>APPENDIX B - IMMFC04 MULTI-FUNCTION CONTROLLER</b> .....	<b>B-1</b>
INTRODUCTION .....	B-1

## Table of Contents (continued)

	<i>Page</i>
<b>APPENDIX C - IMMFC05 MULTI-FUNCTION CONTROLLER.....</b>	<b>C-1</b>
INTRODUCTION .....	C-1
<b>APPENDIX D - INPPT01 PLANT LOOP TO PLANT LOOP TRANSFER MODULE .....</b>	<b>D-1</b>
INTRODUCTION .....	D-1
<b>APPENDIX E - INPCT01 PLANT LOOP TO COMPUTER TRANSFER MODULE.....</b>	<b>E-1</b>
INTRODUCTION .....	E-1
<b>APPENDIX F - INICT01 INFI-NET TO COMPUTER TRANSFER MODULE.....</b>	<b>F-1</b>
INTRODUCTION .....	F-1

## List of Figures

<i>No.</i>	<i>Title</i>	<i>Page</i>
1-1.	Example Redundant IMF Termination Module Application .....	1-1
1-2.	Example Plant Loop to ComputerInterface Application .....	1-2
1-3.	Example Plant Loop to Plant Loop Interface Application .....	1-3
2-1.	NIMF01 Connector Assignments and Dipshunt Locations .....	2-3
2-2.	NIMF02 Connector Assignments and Dipshunt Locations .....	2-4
2-3.	Dipshunt Configuration for Direct Connection to Host Computer (MFC and ICT modules) .....	2-5
2-4.	Dipshunt Configuration for Direct Connection to Modem (MFC and ICT modules) .....	2-6
2-5.	Dipshunt Configuration for Diagnostic Terminal (MFC and ICT modules) .....	2-7
2-6.	Dipshunt Configuration for Direct Connection to Mainframe Computer (ICT module).....	2-8
2-7.	Dipshunt Configuration for PPT Module Acting as DTE (requires modem or other DCE) .....	2-9
2-8.	Dipshunt Configuration for Direct Connection of Local PPT Module Acting as DTE .....	2-10
2-9.	Dipshunt Configuration for Direct Connection of Remote PPT Module Acting as DCE .....	2-11
2-10.	Dipshunt Configuration for Diagnostic Terminal (PPT module) .....	2-12
2-11.	Dipshunt Configuration for Rochester 3800and ESA Control SER-740 .....	2-13
2-12.	Dipshunt Configuration for Rochester ISM.....	2-13
2-13.	NIMF01 Cable Connections .....	2-14
2-14.	NIMF02 Cable Connections .....	2-15
2-15.	DB-25 Pin Assignments and RS-232-C Signals .....	2-15
2-16.	NIMF01 Terminal Assignments .....	2-16
2-17.	NIMF02 Terminal Assignments .....	2-16
A-1.	IMMFC03 CPU Board Layout .....	A-1
B-1.	IMMFC04 Module Layout.....	B-1
C-1.	IMMFC05 Module Layout.....	C-1
D-1.	INPPT01 CPU Board Layout .....	D-1
E-1.	INPCT01 CPU Board Layout .....	E-1
F-1.	INICT01 CPU Board Layout .....	F-1



---

## List of Tables

<i>No.</i>	<i>Title</i>	<i>Page</i>
1-1.	Glossary of Terms and Abbreviations .....	1-5
1-2.	Reference Documents .....	1-5
1-3.	Nomenclature .....	1-6
1-4.	Specifications.....	1-6
2-1.	IMF Cable Applications, Cable Connections and Length Requirements .....	2-14
3-1.	Maintenance Schedule .....	3-1
4-1.	Recommended Spare Parts List .....	4-1
A-1.	IMMFC03 Dipswitch U72 Option Settings .....	A-1
A-2.	IMMFC03 Dipswitch U72 Special Operation Settings .....	A-2
A-3.	IMMFC03 Dipswitch U73 Baud Rate Settings .....	A-3
A-4.	Example IMMFC03 Dipswitch U75 Module Address Settings .....	A-3
B-1.	Example IMMFC04 Dipswitch SW3 Module Address Settings .....	B-1
B-2.	IMMFC04 Dipswitch SW4 Options Settings .....	B-2
B-3.	IMMFC04 Dipswitch SW4 Special Operations Settings .....	B-2
C-1.	Example IMMFC05 Dipswitch SW3 Module Address Settings .....	C-1
C-2.	IMMFC05 Dipswitch SW4 Option Settings .....	C-2
C-3.	IMMFC05 Dipswitch SW4 Special Operation Settings .....	C-2
D-1.	INPPT01 Dipswitch U72 Option Switch Settings .....	D-1
D-2.	INPPT01 Dipswitch U73 Baud Rate Settings .....	D-2
D-3.	Example INPPT01 Dipswitch U75 Loop Address Settings .....	D-3
E-1.	INPCT01 Dipswitch U72 Option Settings .....	E-1
E-2.	INPCT01 Dipswitch U73 Baud Rate Settings .....	E-2
E-3.	Example INPPT01 Dipswitch U75 Loop Address Settings .....	E-3
F-1.	INICT01 Dipswitch U72 Option Settings .....	F-1
F-2.	INPPT01 Dipswitch U73 Baud Rate Settings .....	F-2
F-3.	INICT01 Dipswitch U75 Diagnostics Settings .....	F-3

---

# SECTION 1 - INTRODUCTION

## OVERVIEW

The NIMF01 Multi-Function Controller Termination Module terminates two RS-232-C ports for the IMMFC03 Multi-Function Controller, INICT01 INFI-NET to Computer Transfer Module, INPPT01 Plant Loop to Plant Loop Transfer Module and INPCT01 Plant Loop to Computer Transfer Module. When terminating an IMMFC03 module, it enables the IMMFC03 module to communicate to a computer, terminal, printer or sequential events recorder through the serial ports (see Figure 1-1). It also provides a serial link for a NDCS03 Digital Control Station or IISAC01 Analog Control Station through a NICS01 Control I/O Termination Module. The IMMFC04 and IMMFC05 Multi-Function Controllers). use the NIMF01 termination mod-

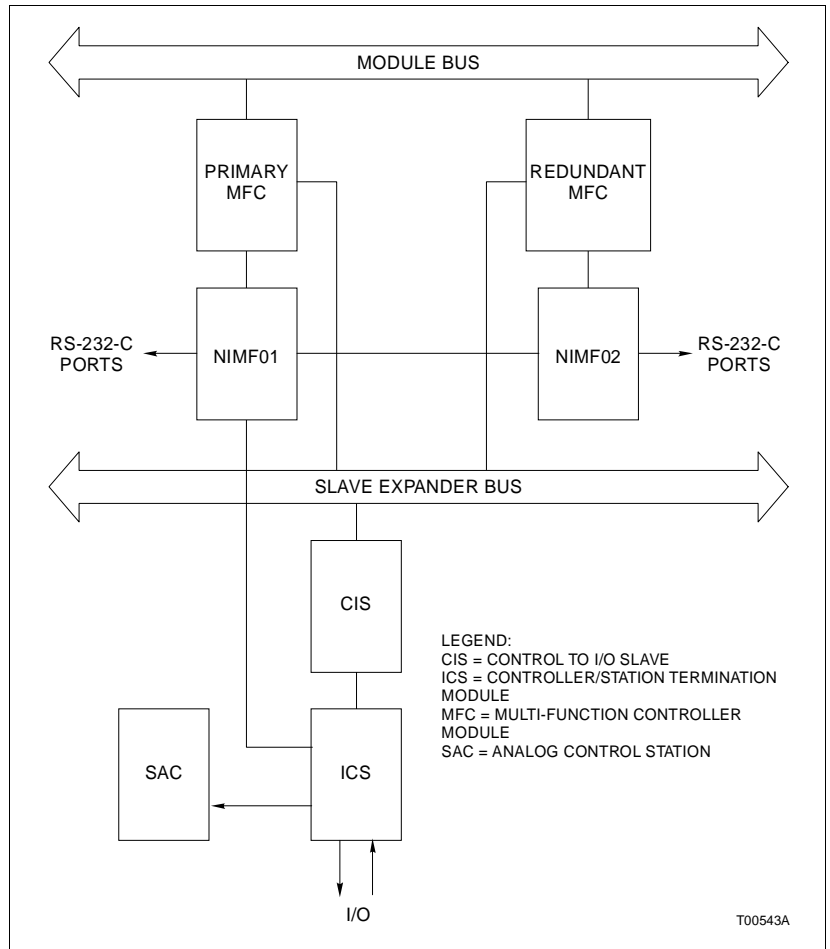

Figure 1-1. Example Redundant IMF Termination Module Application

ule to terminate a station link and connect to a redundant controller.

The NIMF02 termination module is used in addition to the NIMF01 termination module when terminating redundant modules. Figure 1-1 shows an example redundant MFC application. Figure 1-2 shows an example Plant Loop to computer interface application. Figure 1-3 shows an example Plant Loop to Plant Loop interface application. The NIMF02 has on-board relays that allow one MFC module to communicate over the RS-232-C link during redundant operation.

### INTENDED USER

System engineers and technicians should read this manual before installing and placing the multi-function controller termination module (IMF) into operation. **Do not** put the IMF module into operation until this instruction is read and understood.

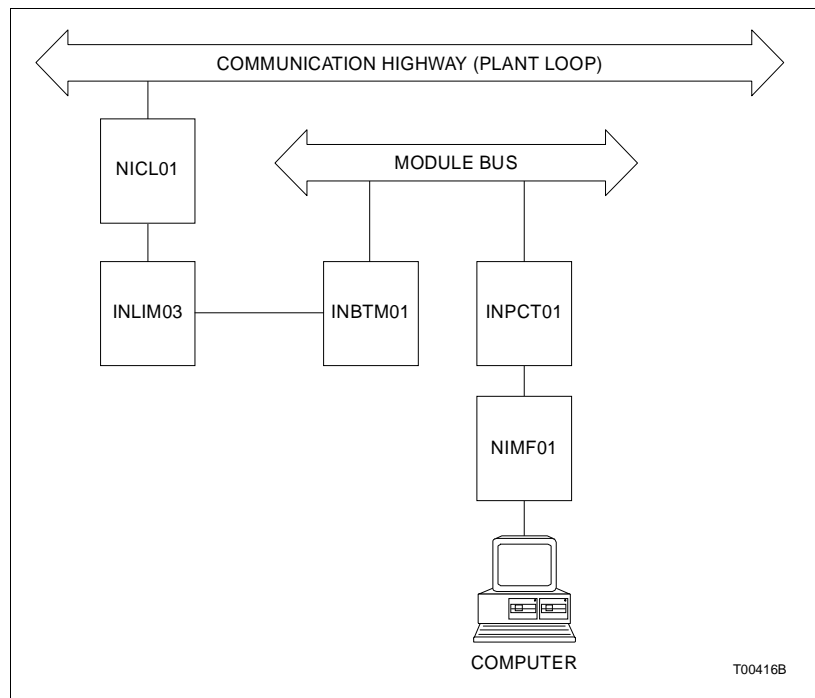

Figure 1-2. Example Plant Loop to Computer Interface Application

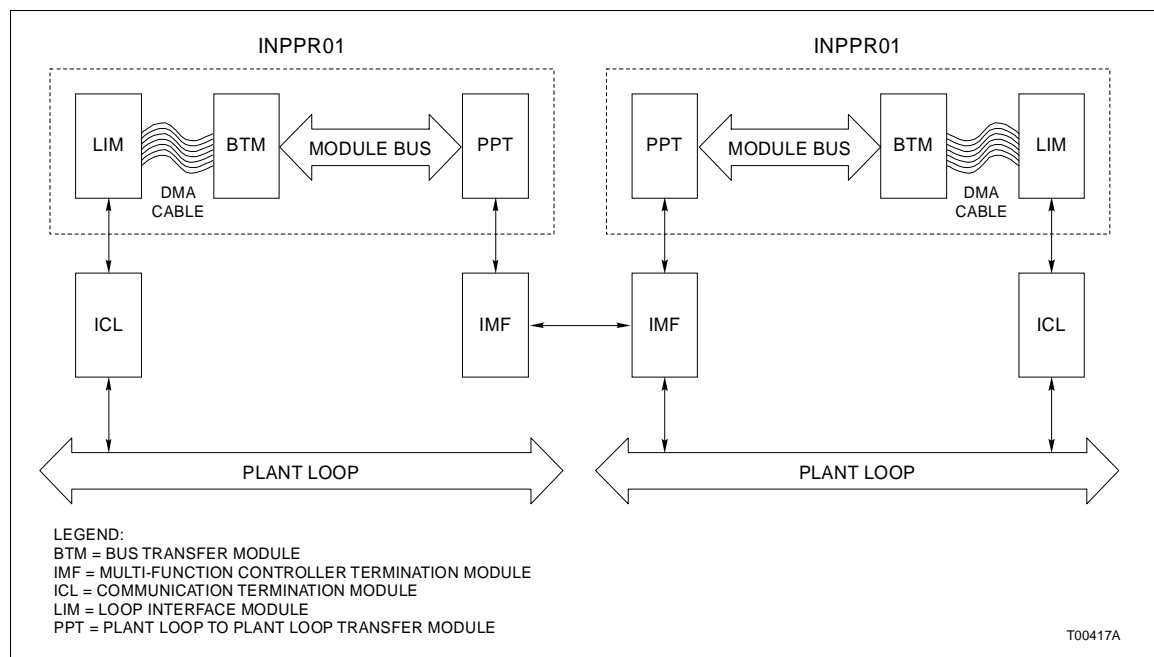

Figure 1-3. Example Plant Loop to Plant Loop Interface Application

## MODULE DESCRIPTION

The IMF module is a single printed circuit board that uses one slot in an NTMU01 or NTMU02 Termination Mounting Unit (TMU). The board contains:

- Two DB-25 connectors.
- Relays (NIMF02 only).
- Connector sockets.
- Dipshunts.
- Light emitting diode (LED).
- Power terminals.
- Serial link terminals (NIMF01 only).

## FEATURES

The IMF termination modules provide serial communication ports for modules. Dipshunts allow the termination module to be configured for operation as DTE or DCE. There is one serial link on the NIMF01 termination module that provides a communication link from a module to an analog control station or digital control station.

---

**HARDWARE APPLICATION**

The IMF termination module is a passive device that terminates the connection of RS-232-C cables from a controller or communication module to a field device (e.g., printer, computer terminal, sequence of events recorder or modem). The computer allows a user to enter control strategies, do module configurations, establish a point table and monitor module status through the computer. Board design gives redundant modules access to both serial ports as well as the serial link to the NICS01 which connects to a NDCS03 Digital Control Station or IISAC01 Analog Control Station.

---

**INSTRUCTION CONTENT**

This manual consists of five sections and six appendices.

<b>Introduction</b>	Contains an overview of the features, specifications and a description of the IMF termination module.
<b>Installation</b>	Describes precautions to observe when handling modules and setup procedures required before module operation. This section discusses dipswitch settings and installation procedures.
<b>Maintenance</b>	Provides a maintenance schedule.
<b>Repair/Replacement Procedures</b>	Details how to replace an IMF termination module.
<b>Support Services</b>	Describes the support services (spare parts, training, documentation, etc.) available from Bailey Controls Company.
<b>Appendices</b>	Briefly discuss the modules that use the IMF termination modules and provide a cross-reference of dipswitch and jumper settings for those modules.

---

**HOW TO USE THIS MANUAL**

Read this manual through in sequence. Read the installation section thoroughly. Do the steps in order. Complete all steps in the installation section before operating the IMF termination module. Refer to the table of contents or index to find specific information after the module is operating.

---

**GLOSSARY OF TERMS AND ABBREVIATIONS**

Table 1-1 lists definitions of the terms and abbreviations used in this instruction.

Table 1-1. Glossary of Terms and Abbreviations

<b>Term</b>	<b>Definition</b>
DCE	Data communication equipment or data circuit terminating equipment. equipment that establishes and terminates a communication link between two devices. In RS-232-C communication systems, the DCE nomenclature indicates the signals that appear at specified cable connection contacts. A modem is an example of this type of device.
Dipshunt	Dual in-line package with shorting straps.
DTE	Data terminal equipment. Equipment comprising the data source, data sink or both that provides the communication control function. In RS-232-C communication systems, the DTE nomenclature indicates the signals that appear at specified cable connection contacts. Terminals and printers are examples of this type of device.
MMU	Module mounting unit. A card cage that provides electrical and communication support for INFI 90/Network 90 <sup>®</sup> modules.
PCB	Printed circuit board.
TM	Termination module. Provides input/output connection between plant equipment and the INFI 90/Network 90 modules.
TMU	Termination mounting unit. A card cage that provides housing for INFI 90/ Network 90 termination modules.

---

## REFERENCE DOCUMENTS

Table 1-2 lists the documents referenced in this instruction.

Table 1-2. Reference Documents

<b>Number</b>	<b>Document Title</b>
I-E93-902	NDCS03 Digital Control Station
I-E96-117	IISAC01 Analog Control Station
I-E96-211	IMMFC03 Multi-Function Controller Module
I-E96-212	IMMFC04 Multi-Function Controller Module
I-E96-213	IMMFC05 Multi-Function Controller Module
I-E96-500	Site Planning and Preparation
I-E96-601	INFI-NET Communications Modules
I-E96-620	INPCI01 Plant Loop to Computer Interface
I-E96-621	INPCI02 Plant Loop to Computer Interface
I-E96-624	INPPR01 Plant Loop to Plant Loop Interface

---

<sup>®</sup> Network 90 is a registered trademark of Eltag Bailey Process Automation.

**NOMENCLATURE**

Table 1-3 is a list of related hardware. Hardware and cables with part numbers are listed in Table 1-4.

*Table 1-3. Nomenclature*

<b>Nomenclature</b>	<b>Hardware</b>
HCBL01	RS-232-C Cable
IISAC01	Analog control station
IMMFC03 IMMFC04 IMMFC05	Multi-function controller module
INICT01	INFI-NET to computer transfer module
NPCT01	Plant Loop to computer transfer module
INPPT01	Plant Loop to plant loop transfer module
NDCS03	Digital control station
NICS01	Control/station termination module
NIDS01	Digital station termination module
NKTM01	Termination module cable (ribbon)
NKTU02	Termination module cable (PVC)
NKTU12	Termination module cable (non-PVC)
NTMU01	Termination mounting unit (rear mount)
NTMU02	Termination mounting unit (front mount)

**SPECIFICATIONS**

Refer to Table 1-4 for the specifications of the NIMF01 and NIMF02 termination modules.

*Table 1-4. Specifications*

<b>Property</b>	<b>Characteristic/Value</b>
<b>Power Requirements</b>	+24 VDC  160 mA current consumption, maximum (the LED consumes 10 mA)
<b>Communication</b>	2 RS-232-C ports  1 serial link for stations
<b>Cable Insulation Specifications</b>	
PVC (UL Rating CL2)	80°C (176°F) at 300 V
Non-PVC (UL Rating PLTC)	90°C (194°F) at 300 V

Table 1-4. Specifications (continued)

Property	Characteristic/Value
<b>Mounting</b>	Slides into a single slot in the termination mounting unit.
<b>Electromagnetic Radio Frequency Interference</b>	Values are not available at this time. Keep cabinet doors closed. Do not use communication equipment any closer than 2 meters from the cabinet.
<b>Cooling Requirements</b>	No cooling necessary when used in Bailey Controls cabinets and operated within stated environmental limits.
<b>Operating Temperature</b>	0°C to 70°C (32°F to 158°F)
<b>Relative Humidity</b>	5% to 90% up to 55°C (131°F) (noncondensing) 5% to 90% up to 70°C (158°F) (noncondensing)
<b>Altitude</b>	Sea level to 3 km (1.86 mi)
<b>Air Quality</b>	Bailey Controls equipment should be operated and stored in a noncorrosive environment.
<b>Certification</b>	All termination modules are CSA certified as process control equipment for use in an ordinary (nonhazardous) location.

SPECIFICATIONS ARE SUBJECT TO CHANGE WITHOUT NOTICE.



---

## SECTION 2 - INSTALLATION

---

### INTRODUCTION

This section lists the steps to properly install the NIMF01 and NIMF02 Multi-Function Controller Termination Modules. The installation procedure includes physical installation, dipshunt configuration, cable connection, power wiring and handling. To properly install the IMF termination module do the steps in this section in the order they appear.

---

### SPECIAL HANDLING

Observe these steps when handling electronic circuitry:

**NOTE:** Always use Bailey Controls field static kit (part number 1948385A1 - consisting of two wrist straps, ground cord assembly, alligator clip, and static dissipative work surface) when working with the modules. The kit grounds a technician and the static dissipative work surface to the same ground point to prevent damage to the modules by electrostatic discharge.

1. **Use Static Shielding Bag.** Keep the modules in the static shielding bag until you are ready to install them in the system. Save the bag for future use.
2. **Ground Bag Before Opening.** Before opening a bag containing an assembly with CMOS devices, touch it to the equipment housing or a ground to equalize charges.
3. **Avoid Touching Circuitry.** Handle assemblies by the edges; avoid touching the circuitry.
4. **Avoid Partial Connection of CMOS Device.** Verify that all devices connected to the modules are properly grounded before using them.
5. **Ground Test Equipment.**
6. **Use an Antistatic Field Service Vacuum.** Remove dust from the module if necessary.
7. **Use a Grounded Wrist Strap.** Connect the wrist strap to the appropriate grounding plug on the power entry panel. The grounding plug on the power entry panel is connected to the earth grounding electrode system through the AC safety ground.
8. **Do Not Use Lead Pencils to Set Dipswitches.** To avoid contamination of dipswitch contacts that can result in unnecessary circuit board malfunction, do not use a lead pencil to set a dipswitch.

---

**UNPACKING AND INSPECTION**

1. Examine the hardware immediately for shipping damage.
2. Notify the nearest Bailey Controls sales office of any such damage.
3. File a claim for any damage with the transportation company that handled the shipment.
4. Use the original packing material and container to store the hardware.
5. Store the hardware in an environment of good air quality, free from temperature and moisture extremes.

---

**SETUP/PHYSICAL INSTALLATION**

This section explains how to configure and install the IMF termination module. Configure the dipshunts before installing the IMF termination module. There are four dipshunts, two for each RS-232-C port. These dipshunts define the active handshake lines. Each port can be configured as a DTE or DCE device. Only port two can terminate a diagnostic terminal. The IMF termination modules can interface to:

- Device.

Printer.

Sequence of events recorder.

IBM<sup>®</sup>PC.

COMPAQ<sup>®</sup> and compatible computers.

- Terminals.

VT1XX.

ADM3.

VISUAL 50.

WYSE (WY50).

TELEVIDEO.

FALCO.

**NOTES:**

1. The IMMFC04 and IMMFC05 Multi-Function Controller Modules use the IMF termination module for its link to stations and for connecting a redundant MFC module. They do not have serial communication capabilities. Therefore, no dipshunts are required when terminating the IMMFC04 or IMMFC05 modules.

2. Only the IMMFC03 Multi-Function Controller module drives the IMF termination modules LED. The LED will not light when the IMF termination module is used with an IMMFC04 or IMMFC05 Multi-Function Controller module.

---

<sup>®</sup> IBM is a registered trademark of International Business Machines Corporation.

<sup>®</sup> COMPAQ is a registered trademark of COMPAQ Corporation

**Dipshunt Configuration for DTE or DCE**

Configure dipshunts XU1 or XU2 and XU3 or XU4 so that their respective ports operate as DTE or DCE. Port two can be used to interface a diagnostic terminal. Figure 2-1 shows the connector assignments and dipshunt location on the NIMF01 termination module. Figure 2-2 shows the connector assignments and dipshunt location on the NIMF02 termination module. Install the appropriately cut dipshunts using Figures 2-3 and 2-4.

**NOTES:**

1. The IMF termination module dipshunt settings shown in Figures 2-3, 2-4, and 2-5 apply to the MFC and INICT01 modules. Figure 2-6 applies only to the INICT01 module. Figures 2-7, 2-8, and 2-9 show the dipshunt settings required when using the IMF termination module to terminate an INPPT01 module.
2. If an isolating modem is used, and pins one (protective ground) and seven (signal common ground) of the modem connector are tied together, dipshunt strap three of XU2 and XU4 must be cut. Doing this maintains the isolation of DC common and safety ground within the INFI 90/Network 90 system.

**Dipshunt Configuration for a Mainframe Computer**

The INICT01 and INPCT01 modules can interface to a mainframe computer (MODCOMP or VAX). To set up the IMF termination module to terminate a mainframe, refer to Figure 2-6

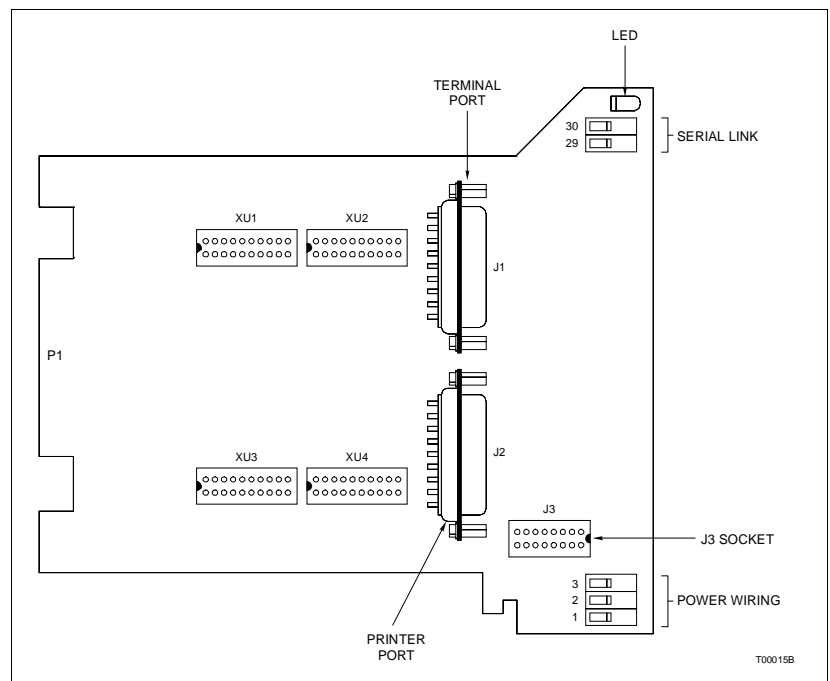

Figure 2-1. NIMF01 Connector Assignments and Dipshunt Locations

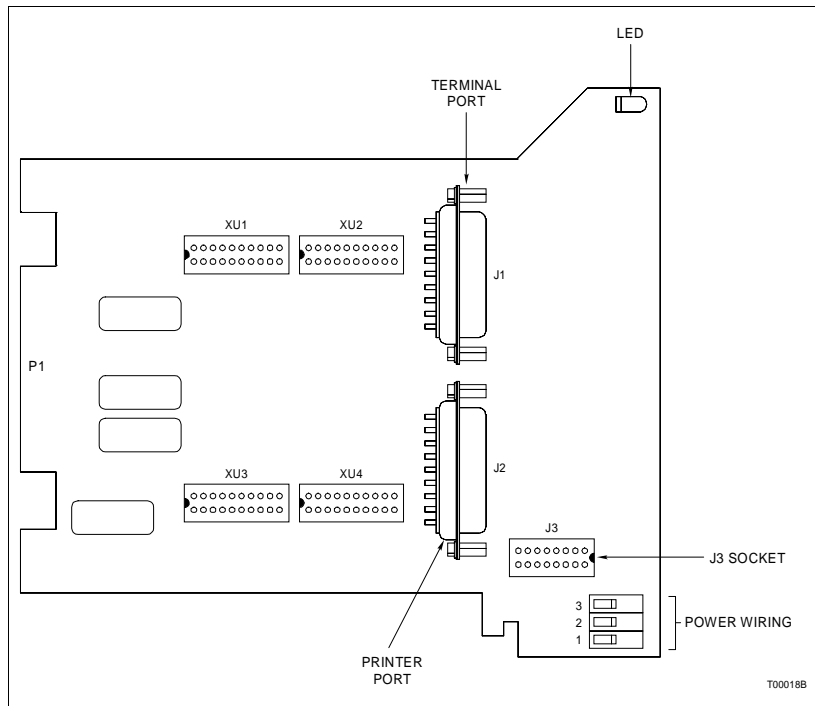

Figure 2-2. NIMF02 Connector Assignments and Dipshunt Locations

and install the appropriate set of dipshunts (XU1 or XU2 and XU3 or XU4) as shown.

**Dipshunt Configuration for the INPPT01 Module**

When the IMF termination module is used to terminate an INPPT01 module, use the dipshunt settings shown in Figures 2-7 through 2-10. To install the dipshunts:

1. If connecting a local Plant Loop (DTE) to a remote Plant Loop (DTE) through a modem or microwave link (DCE), use the dipshunt settings shown in Figure 2-7. Set the IMF module for both the local and remote PPT to the dipshunt settings shown.
2. If connecting a local Plant Loop (DTE) directly to a remote Plant Loop (DTE) via a cable (DCE), use the dipshunt settings shown in Figure 2-8 (local) and Figure 2-9 (remote).
3. To connect a diagnostic terminal to the INPPT01 module, use port two on the IMF module and the dipshunt settings shown in Figure 2-10.

**Sequence of Events Recorder**

The IMF termination module interfaces with the Rochester 3800, Rochester ISM and ESA Controls SER-740 Sequence of

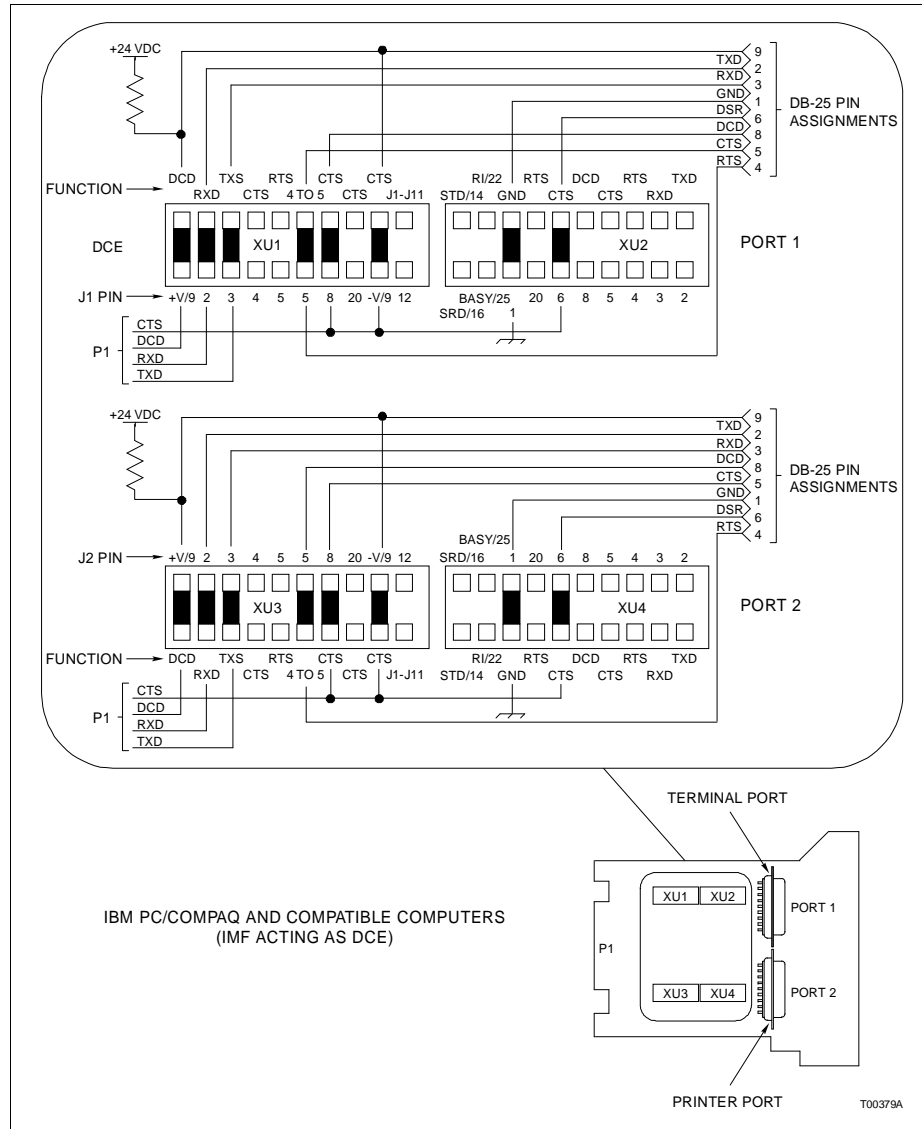

Figure 2-3. Dipshunt Configuration for Direct Connection to Host Computer (MFC and ICT modules)

Events recorders. Refer to Figures 2-11 and 2-12 for dipshunt configurations.

**Cabling Connections**

Figure 2-13 shows the cable connections from the NIMF01 termination module to the primary module. Figure 2-14 shows the cabling connection for redundancy using the NIMF02 termination module. Table 2-1 lists the IMF termination module cable applications.

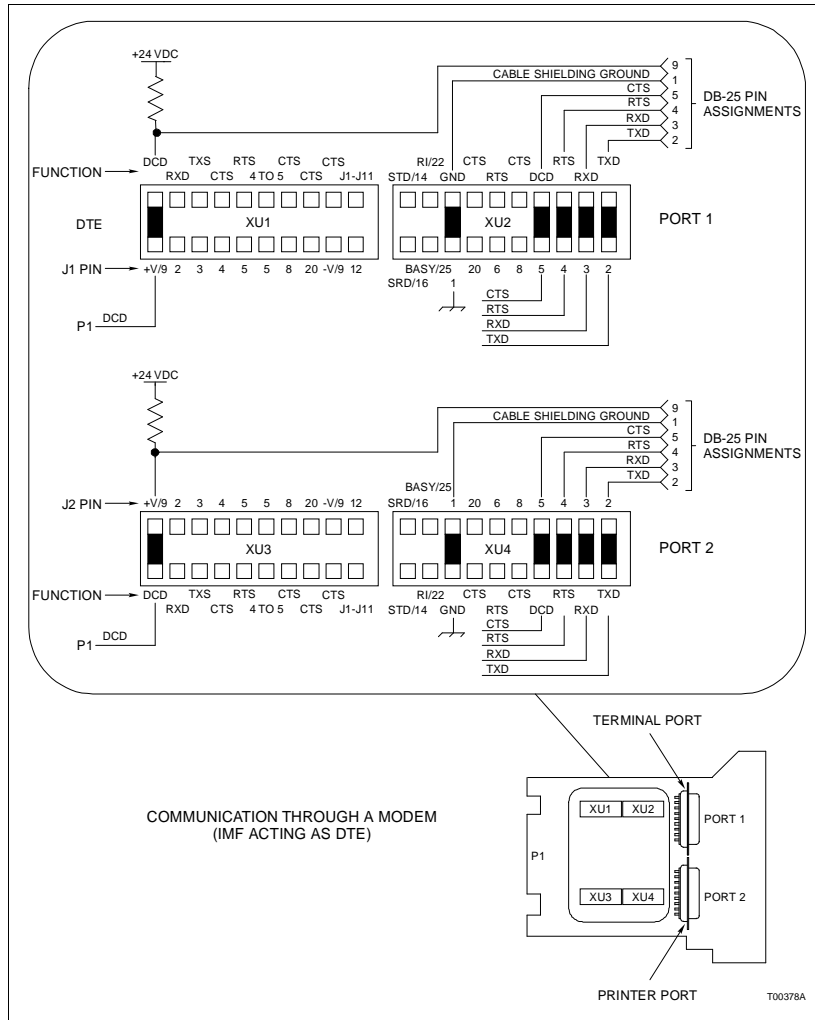

Figure 2-4. Dipsshunt Configuration for Direct Connection to Modem (MFC and ICT modules)

**Cable Installation**

**CAUTION**

Remove a module from its assigned slot before installing or removing a cable assigned to that slot. Failure to do so could result in damage to the module.

**ATTENTION**

Avant de retirer ou de brancher un câble, retirez le module logé dans la coulisse correspondante. Autrement, le module risque d'être endommagé.

Figures 2-13 and 2-14 show the cable connections between the modules, termination modules, and output devices. The cable from the IMF termination module to the module can be either the NKTU02 or NKTU12 Termination Module Cable (round cable) or the NKTMO1 Termination Module Cable (ribbon cable).

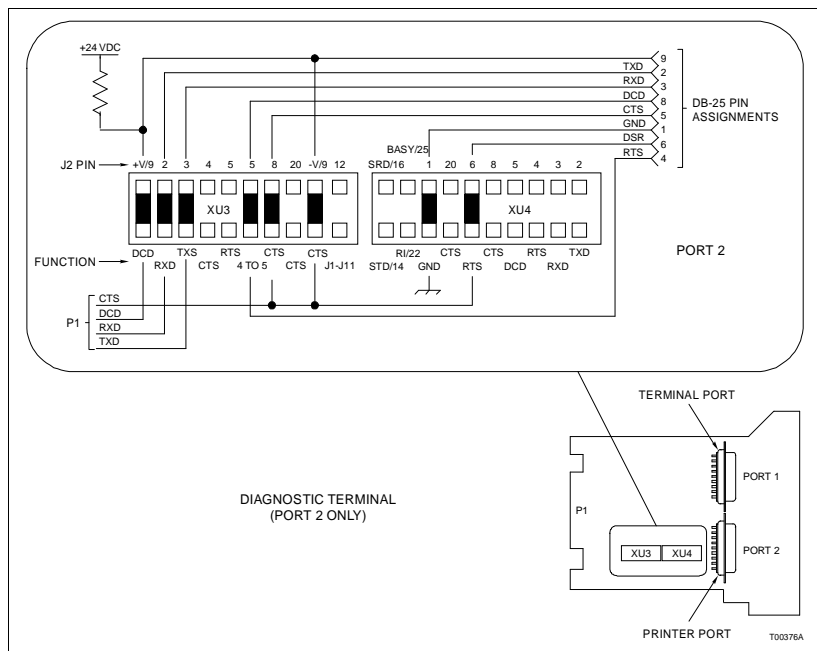

Figure 2-5. Dipshunt Configuration for Diagnostic Terminal (MFC and ICT modules)

**NKTM01**

This cable connects the NIMF01 termination module to the primary module and the NIMF02 termination module to the redundant module. The NKTM01 cable is a flat ribbon cable (30 meters or 100 feet maximum). Do not bundle the ribbon cable with other wiring. Bundling the cable can cause cross talk in the ribbon cable. To install the cable:

**NOTE:** If the module is installed, pull it several inches from the backplane before installing the cable.

1. Insert one end of the cable into the module mounting unit backplane slot assigned to the module. The cable should latch securely in place. Card edge connector P3 of the module connects to this end of the cable.
2. Insert the other end of the cable into the termination mounting unit (TMU) backplane slot assigned to the IMF termination module. The cable should latch securely in place. Card edge connector P1 of the IMF termination module connects to this end of the cable.

**NKTU02 OR NKTU12**

This cable connects the NIMF01 termination module to the primary module and the NIMF02 termination module to the redundant module. The NKTU02 or NKTU12 cable is a round

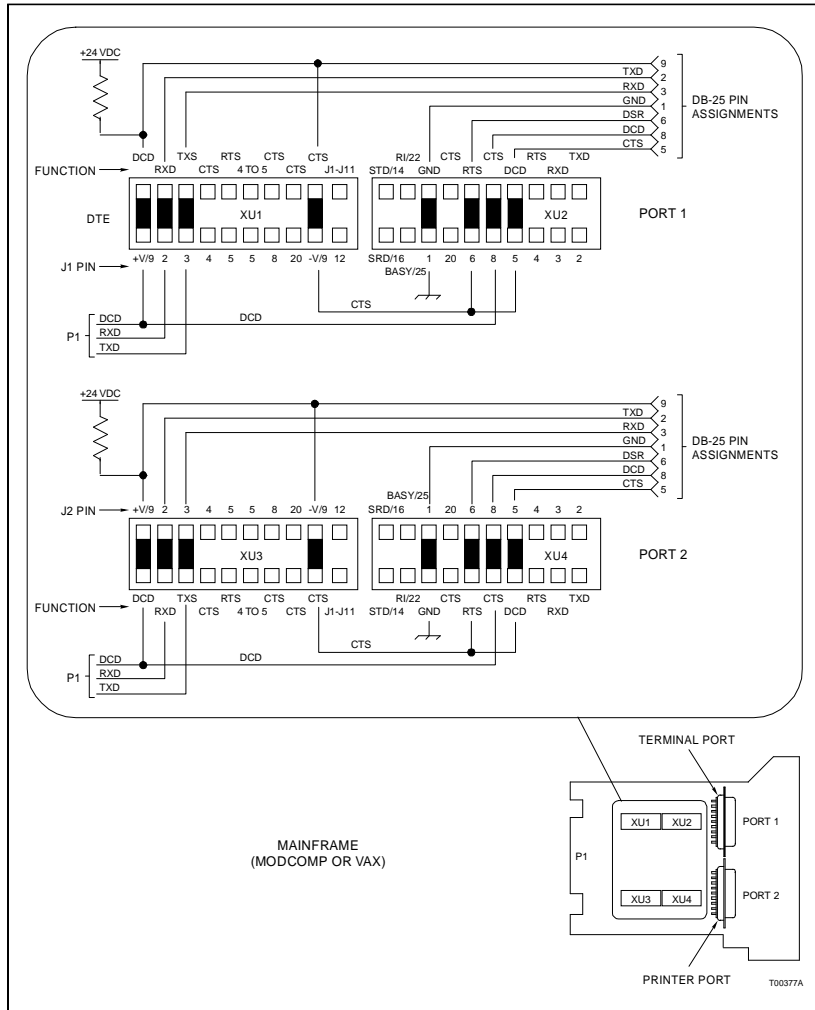

Figure 2-6. Dipshunt Configuration for Direct Connection to Mainframe Computer (ICT module)

cable (61 meters or 200 feet maximum). The cable is shielded. To install the cable:

**NOTE:** If the module is installed, pull it several inches from the backplane before installing the cable.

1. Insert the J2 end of the cable into the module mounting unit backplane slot assigned to the module. The cable should latch securely in place. Card edge connector P3 of the module connects to this end of the cable.
2. Connect the shield wire from the J2 end to the shield bus bar.
3. Insert the J1 end of the cable into the termination mounting unit (TMU) backplane slot assigned to the IMF termination module. The cable should latch securely in place. Card edge



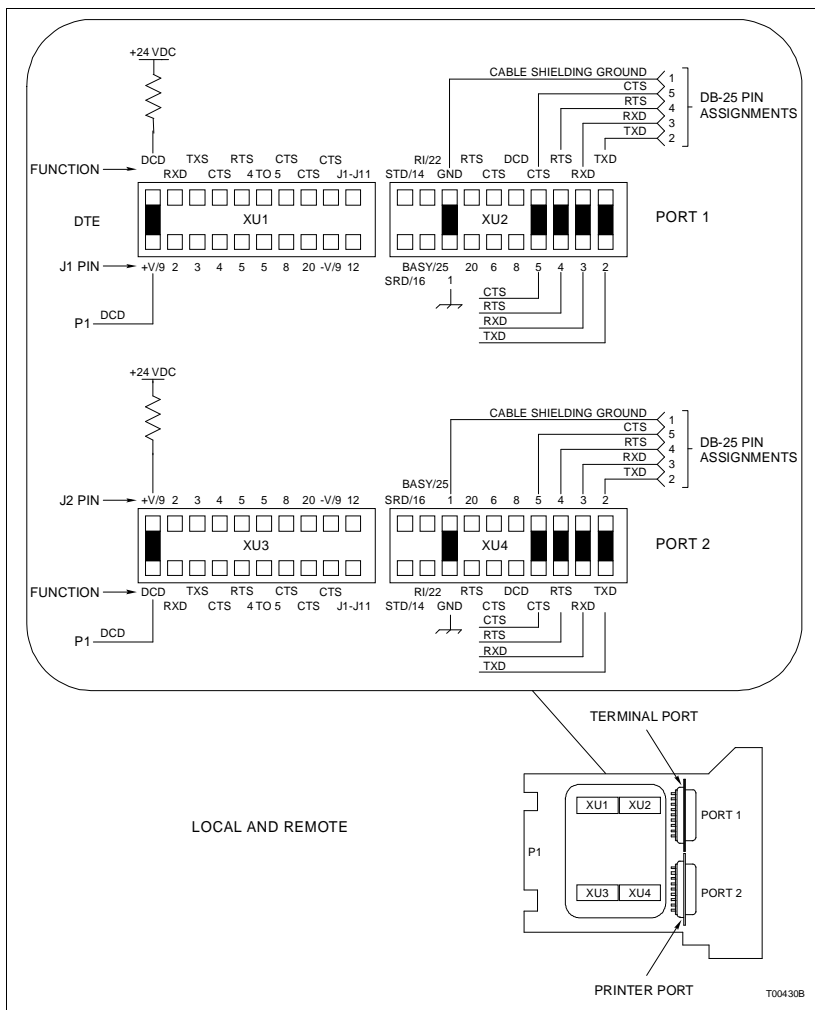

Figure 2-7. Dipshunt Configuration for PPT Module Acting as DTE (requires modem or other DCE)

connector P1 of the IMF module connects to this end of the cable.

4. Install a cable retaining bracket to the rear of the TMU unit.

### RS-232-C COMMUNICATION CABLE

The RS-232-C communication cable connects the IMF module to a computer, terminal, printer or modem (see Figure 2-14). Table 2-1 lists the requirements of the RS-232-C cable, its application, connector assignments and length restrictions. Figure 2-15 shows the DB-25 connector pin assignments. To install the RS-232-C cable:

1. Turn off power to host computer or terminal.

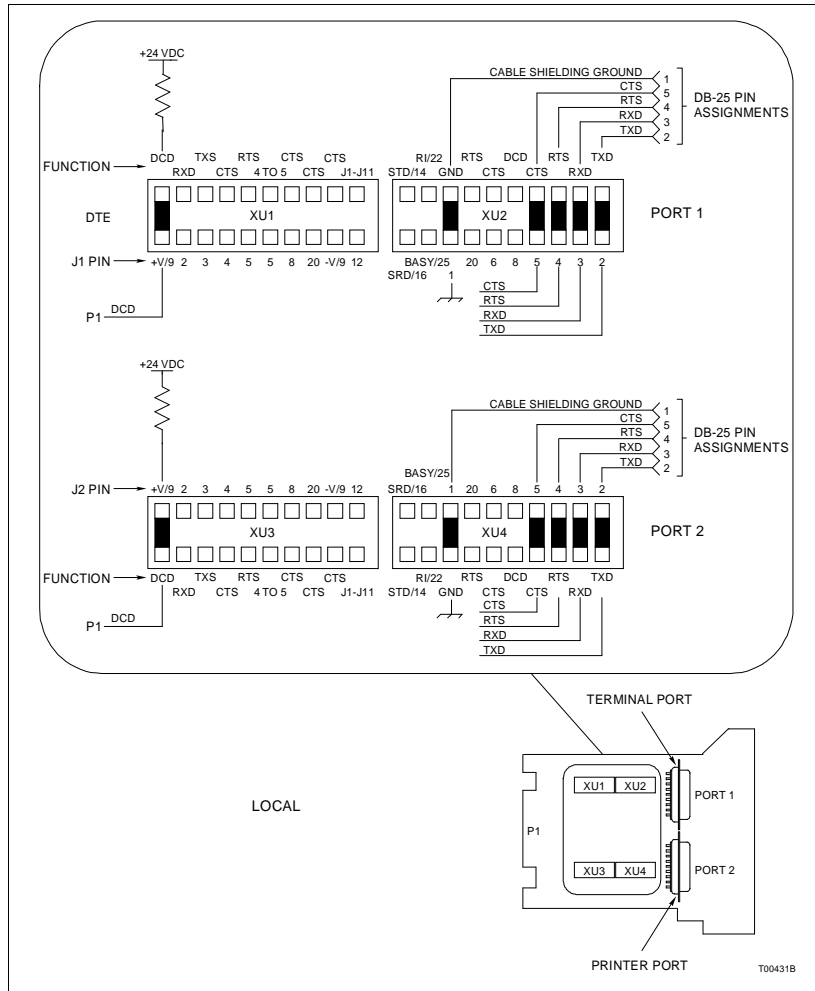

Figure 2-8. Dipshunt Configuration for Direct Connection of Local PPT Module Acting as DTE

2. Install the RS-232-C cable to the DB-25 connector on the IMF marked J1 for port one. Connect the other end of the RS-232-C cable to the external device.
3. Install the RS-232-C cable to the DB-25 connector on the IMF marked J2 for port two. Connect the other end of the RS-232-C cable to the external device.

**RIBBON CABLE 6634408A2**

This cable connects the NIMF01 and NIMF02 termination modules for redundant module configuration. To install the cable:

1. Insert one end of the cable into the J3 socket of the NIMF01 module.

2. Insert the other end of the cable into the J3 socket of the NIMF02 module.

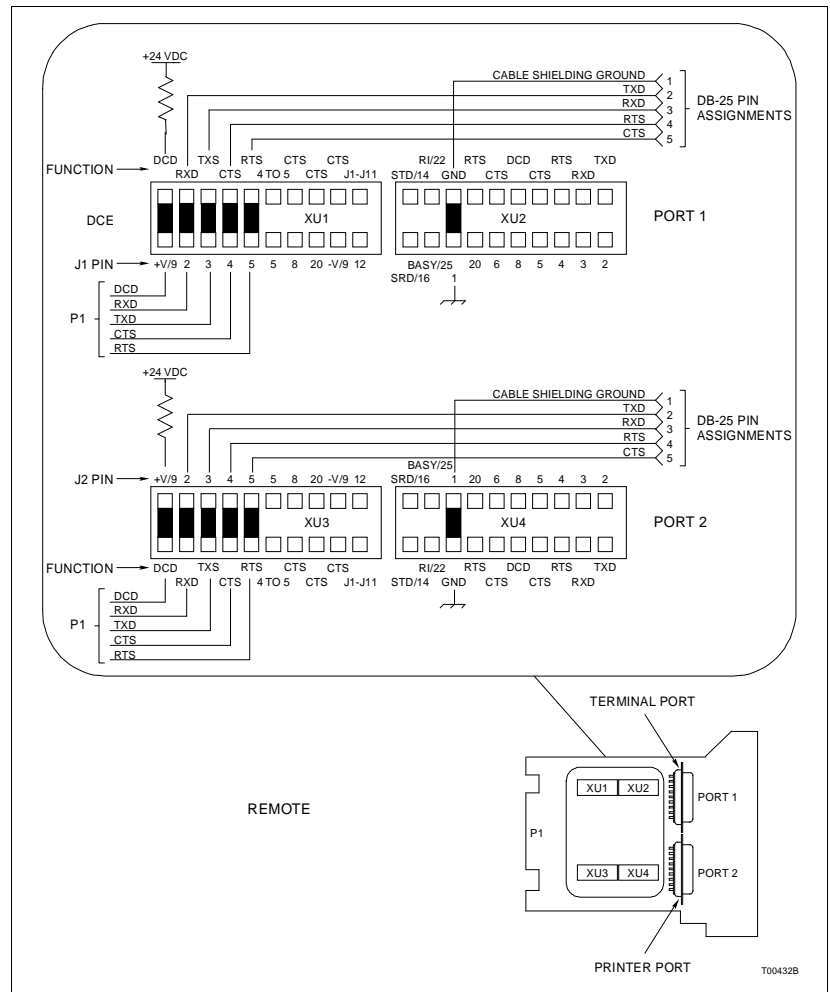

Figure 2-9. Dipshunt Configuration for Direct Connection of Remote PPT Module Acting as DCE

### Installing the Termination Module

The IMF termination module inserts into a standard INFI 90 Termination Mounting Unit (TMU) and occupies one slot. To install:

1. Verify the slot assignment of the IMF module.
2. Align the IMF termination module with the guide rails in the termination mounting unit and partially insert the module.
3. Push down the plastic stop and insert the module until it is latched into the TMU unit.
4. Install the front cover.

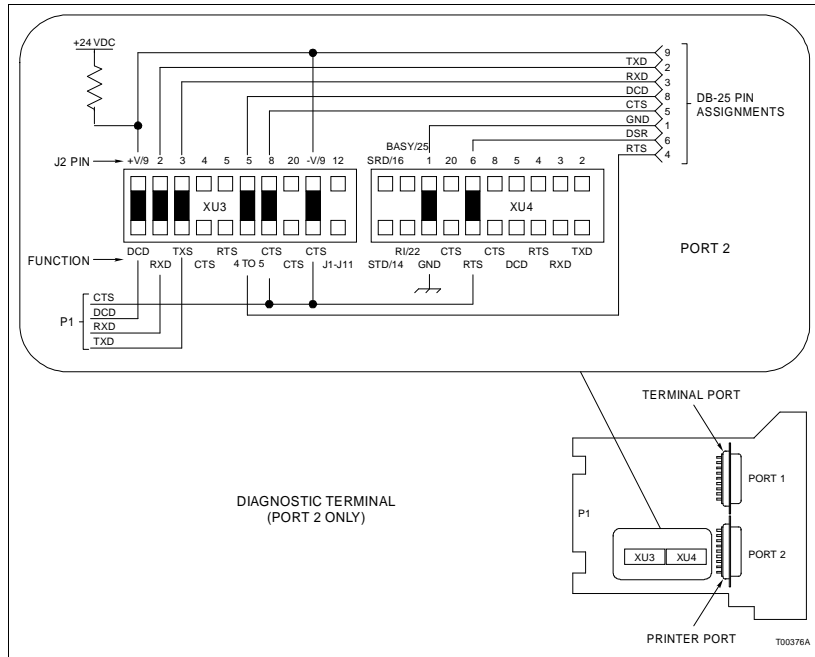

Figure 2-10. Dipshunt Configuration for Diagnostic Terminal (PPT module)

Terminal Wiring

CAUTION

It is strongly recommended that all power (cabinet, I/O, etc.) be turned off before doing any termination module wiring. Failure to do so could result in equipment damage. Do not apply power until all connections are verified.

ATTENTION

Il est fortement recommand, que toutes les alimentations (armoire, E/S, etc.) soient coupées avant d'effectuer quelque raccord que ce soit sur un carte de raccordement. Un manquement à ces instructions pourrait causer des dommages à l'équipement. Ne pas rebrancher les alimentations avant d'avoir vérifié tous les raccordements.

Serial link and power wiring must be connected to the NIMF01 terminal strip. See Figure 2-16 for NIMF01 termination module terminal strip assignments. The NIMF02 only has power wiring terminals. Figure 2-17 shows the NIMF02 terminal strip assignments.

**NOTE:** Proper polarity of all signals must be maintained.

To connect serial link and power wiring:

1. Remove the front cover.

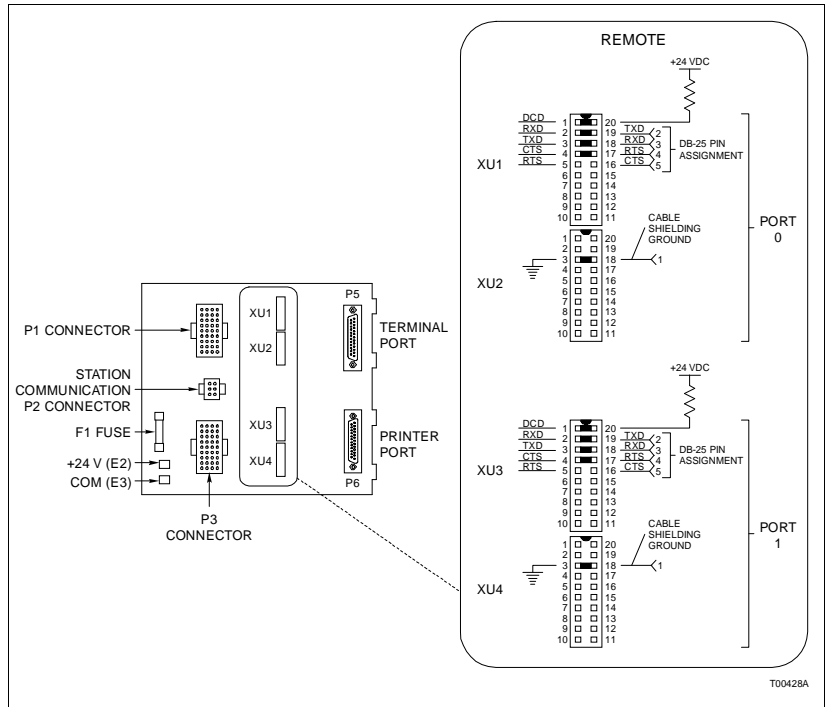

Figure 2-11. Dipshunt Configuration for Rochester 3800 and ESA Control SER-740

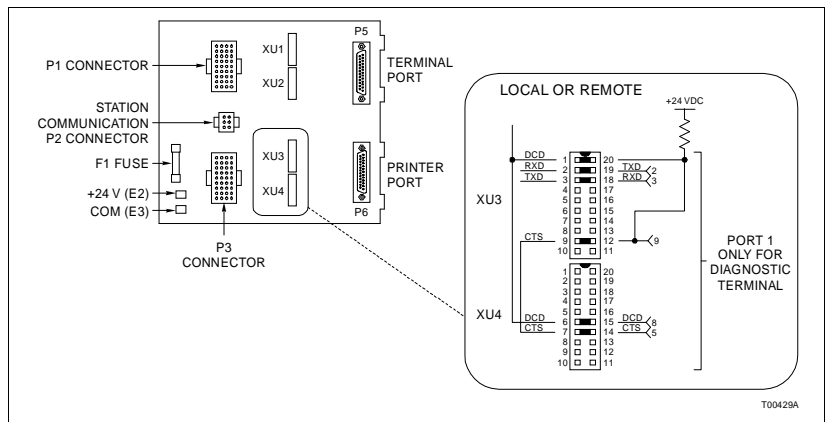

Figure 2-12. Dipshunt Configuration for Rochester ISM

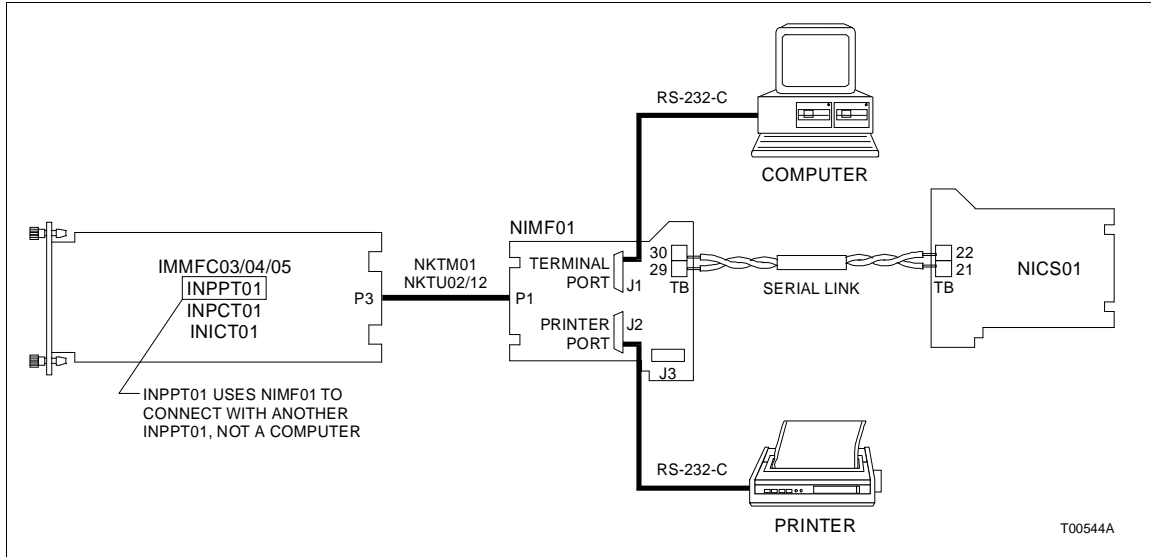

Figure 2-13. NIMF01 Cable Connections

Table 2-1. IMF Cable Applications, Cable Connections and Length Requirements

Cable	Connections				Maximum Length	
	From		To			
HCBL01	DCE or DTE device	DB-25	NIMP01	J1 or J2	15	50 <sup>1</sup>
NKTU01	NIMF01	P1	Primary module	P3	30	100
	NIMF02	P1	Redundant module	P3	30	100
NKTU02 or NKTU12	NIMF01	P1	Primary module	P3	61	200
	NIMF02	P1	Redundant module	P3	61	200
R2041-1976	NIMF01	TB29 and TB30	NICS01	TB21 and TB22	457	1500
6645508A2	NIMF01	J3	NIMF02	J3	30	100

**NOTE:**

1. The specified maximum length only applies to the HCBL01 cable. The performance of INFI 90 modules do not place a restriction on the maximum length of the RS-232-C cable. Follow industry-wide accepted RS-232-C practices and rules when selecting a suitable RS-232-C cable for your system.

2. Ensure the IMF module is pulled out far enough to gain access to the terminal strip.
3. Feed the serial link wiring into the terminal strip area and connect them to the appropriate terminals.

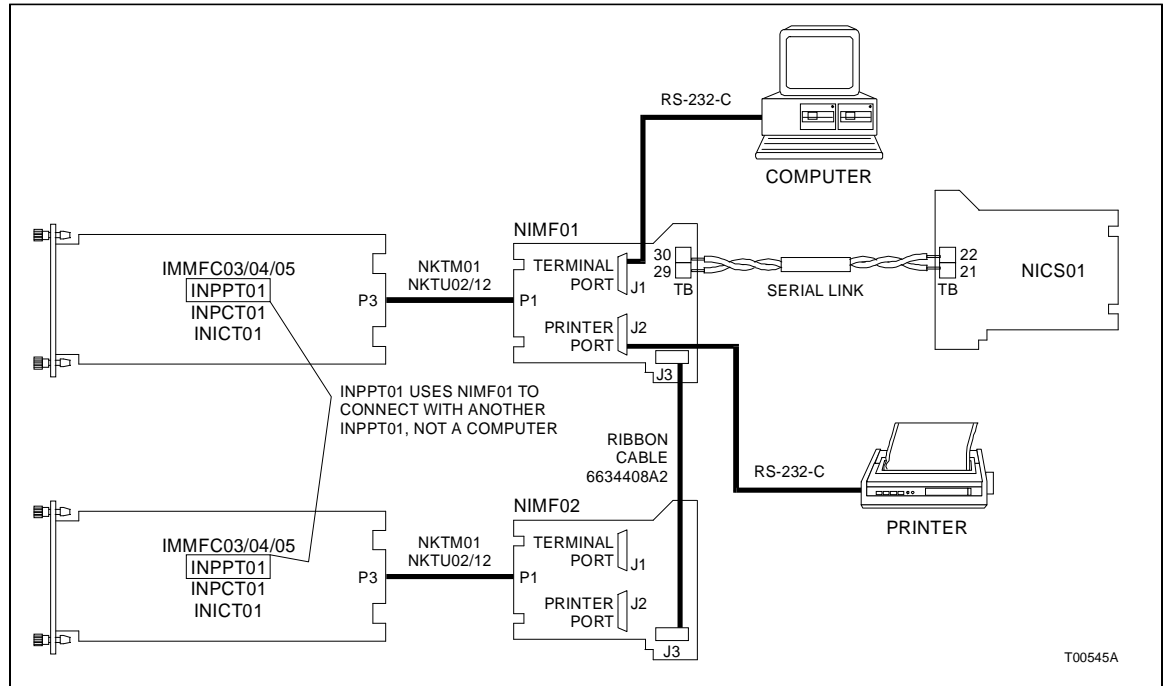

Figure 2-14. NIMF02 Cable Connections

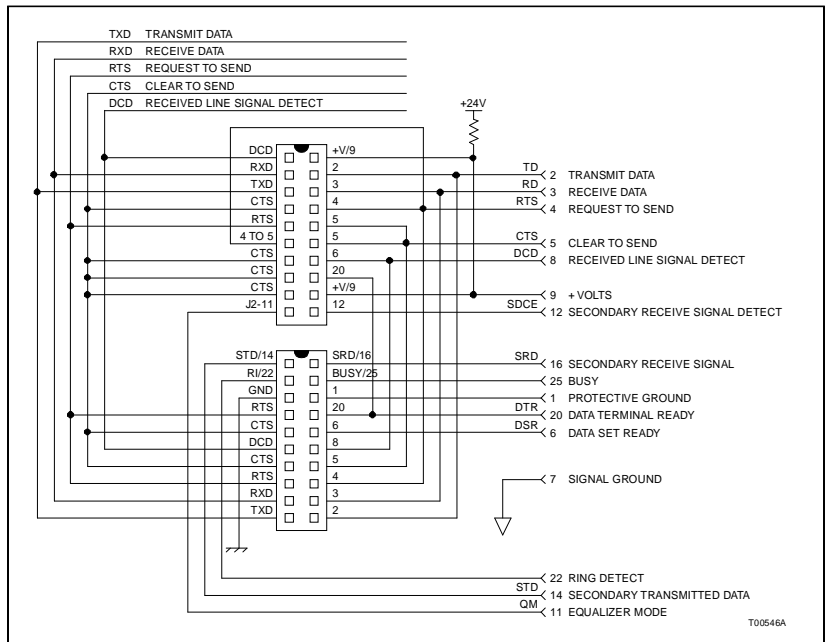

Figure 2-15. DB-25 Pin Assignments and RS-232-C Signals

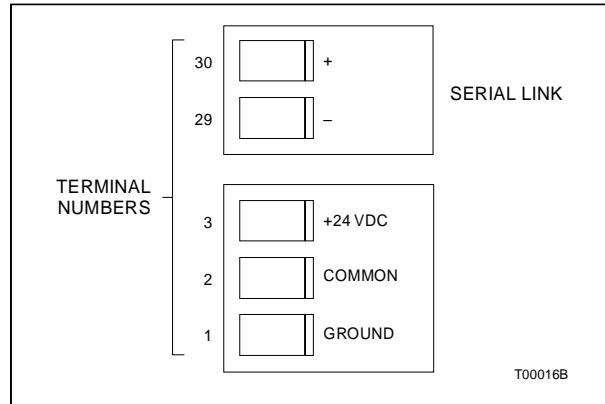

Figure 2-16. NIMF01 Terminal Assignments

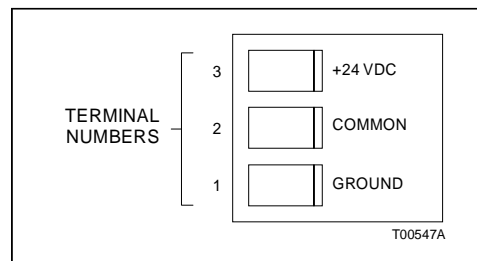

Figure 2-17. NIMF02 Terminal Assignments

4. Connect an 18 AWG wire from the +24 VDC bus of the termination mounting unit to the +24 VDC terminal of the IMF module.
5. Connect an 18 AWG wire from the common bus of the termination mounting unit to the common terminal of the IMF module.
6. Connect an 18 AWG wire from the chassis ground terminal of the IMF module to the cabinet chassis ground bolt.
7. Insert the module until it locks securely into place.
8. Replace (snap on) the front cover.

The IMF termination module is ready for operation if:

1. The fuses are installed.
2. The cable is installed and verified.
3. All field wiring is complete.
4. Power is connected and applied to the IMF module.



---

## SECTION 3 - MAINTENANCE

---

### **INTRODUCTION**

The multi-function controller termination modules (IMF) require limited maintenance. This section contains a maintenance schedule.

---

### **MAINTENANCE SCHEDULE**

Execute the tasks in Table 3-1 at the specified intervals.

*Table 3-1. Maintenance Schedule*

<b>Task</b>	<b>Interval</b>
Clean and tighten all power and field wiring connections.	Every 6 months or during plant shut-down, whichever occurs first.
Use a static safe vacuum cleaner to remove dust from: Termination modules. Termination mounting unit.	

---

## SECTION 4 - REPAIR/REPLACEMENT PROCEDURES

---

### INTRODUCTION

This section explains the replacement procedures for the multi-function controller termination modules (IMF).

---

### MODULE REPLACEMENT PROCEDURES

If an IMF termination module is faulty, replace it with a new one. Table 4-1 lists the recommended spare parts.

**NOTES:**

1. When replacing a termination module, verify that the dipshunt settings on the replacement termination module are the same as the failed termination module.
2. Turn off power to the computer, modem or diagnostic terminal before pulling the termination module out of its slot to remove the RS-232-C cables from the IMF termination module.

*Table 4-1. Recommended Spare Parts List*

Description	Part Number
Ribbon cable	6634408A2

**CAUTION**

**It is strongly recommended that all power (cabinet, I/O, etc.) be turned off before doing any termination module wiring. Failure to do so could result in equipment damage. Do not apply power until all connections are verified.**

**ATTENTION**

**Il est fortement recommandé, que toutes les alimentations (armoire, E/S, etc.) soient coupées avant d'effectuer quelque raccord que ce soit sur un carte de raccordement. Un manquement à ces instructions pourrait causer des dommages à l'équipement. Ne pas rebrancher les alimentations avant d'avoir vérifié tous les raccords.**

1. Pull the termination module out of the TMU so that the RS-232-C and power cables are accessible.
2. Turn off power to the cabinet and disconnect the +24 VDC, common and chassis ground wiring from TB1, TB2 and TB3 of the termination module. Mark the cables according to their terminal assignments as you remove them.
3. If there is a serial link to a station termination module, disconnect the serial link from TB29 and TB30. Mark the cables according to their terminal assignments as you remove them. The NIMF02 does not have a serial link connection.

4. If there is a redundant termination module (an NIMF01 and NIMF02) disconnect the ribbon cable from the J3 socket on the faulty termination module.
5. Remove the RS-232-C cables from the DB-25 connectors on the faulty IMF termination module. Mark the cables according to their connector assignments as you remove them.
6. When all cables are removed from the termination module, pull it out of the TMU unit.
7. Align the replacement termination module with the guide rails of its assigned slot in the TMU unit.
8. Partially insert the replacement termination module and connect the RS-232-C cables, power wiring, serial link and ribbon cable.
9. After all cables and wires have been replaced, slide the termination module into the TMU unit until its card edge seats in the card edge connector of the termination module cable on the backplane of the TMU unit.
10. Return power to the computer, modem or diagnostic terminal. Return power to the cabinet containing the IMF termination module.

---

## SECTION 5 - SUPPORT SERVICES

---

### *INTRODUCTION*

Bailey Controls Company is ready to help in the use, application and repair of its products. Contact the nearest sales office to make requests for sales, applications, installation, repair, overhaul and maintenance contract services.

---

### *REPLACEMENT PARTS AND ORDERING INFORMATION*

When making repairs, order replacement parts from a Bailey sales office.

1. Part description, part number and quantity.
2. Model and serial numbers (if applicable).
3. Bailey Controls instruction manual number, page number and reference figure that identifies the part.

Order parts without commercial descriptions from the nearest Bailey Controls Company sales office.

---

### *TRAINING*

Bailey Controls Company has a modern training facility available for training your personnel. On-site training is also available. Contact a Bailey Controls sales office for specific information and scheduling.

---

### *TECHNICAL DOCUMENTATION*

Additional copies of this manual, or other Bailey Controls Company manuals, can be obtained from the nearest Bailey Controls Company sales office at a reasonable charge.

# APPENDIX A - IMMFC03 MULTI-FUNCTION CONTROLLER

## INTRODUCTION

Several dipswitches must be set for the IMMFC03 Multi-Function Controller Module. The IMMFC03 module consists of two circuit boards: a memory board and a CPU board. The memory board has no user configurable operating options. The CPU board has three dipswitches that set the module operating characteristics. Figure A-1 shows the CPU board layout. Tables A-1 through A-4 explain the dipswitch settings for the CPU board. For more information on the module, refer to the **IMMFC03 Multi-Function Controller Module** product instruction.

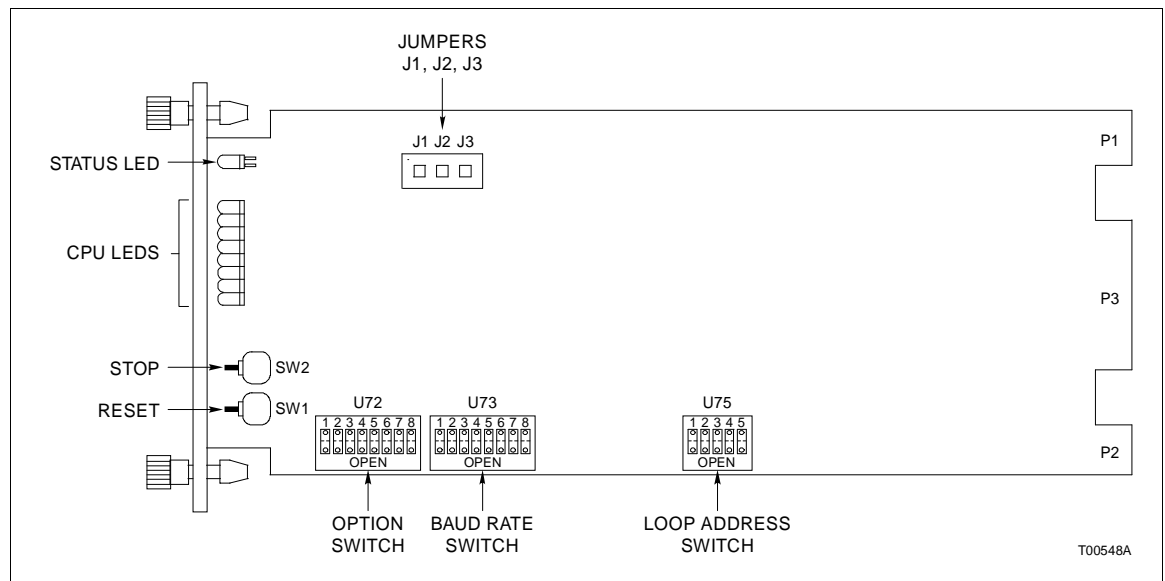

Figure A-1. IMMFC03 CPU Board Layout

Table A-1. IMMFC03 Dipswitch U72 Option Settings

Position	Setting	Function
1	0	Normal operation.
	1	Enable special operations (refer to Table A-2).
2	0	Disable on-line configuration.
	1	Enable on-line configuration.
3	0	Perform ROM checksum routine.
	1	Inhibit ROM checksum routine.
4	0	Not used.
5	0	Perform ROM check.
	1	Inhibit ROM (CPU board) check.

Table A-1. IMMFC03 Dipswitch U72 Option Settings (continued)

Position	Setting	Function
6	0	Normal operation.
	1	Compact configuration - moves configured blocks to the top of NVRAM while moving free space to the bottom (this is known as compacting). Leave switch OPEN and insert module into MMU. When front panel LEDs 1, 2 and 4 are ON, remove the module, put the switch in the CLOSED position and insert the module. The MFC goes into the configure mode and compacts the configuration.
7	0	Normal operation.
	1	Initialize NVRAM (erase configuration) - leave switch OPEN and insert the module into the MMU. When front panel LEDs 1, 2 and 4 are ON, remove the module, put the switch in the CLOSED position and insert the module. The module is now ready to be configured. This switch must be CLOSED for normal operation.
8	0	Primary MFC module.
	1	Redundant MFC module.

NOTE: 0 = CLOSED or ON, 1 = OPEN or OFF.

Table A-2. IMMFC03 Dipswitch U72 Special Operation Settings

Special Operation	Dipswitch Position								Description
	1	2	3	4	5	6	7	8	
1	1	0	0	0	0	0	0	1	Reserved for future use. If you use this setting, your module may not operate properly.
2	1	0	0	0	0	0	1	0	Initialize NVRAM configuration space.
3	1	0	0	0	0	0	1	1	Reserved. Do not use. If you use this setting, your module may not operate properly.
4	1	0	0	0	0	1	0	0	INFI-NET protocol enable. This allows the MFC module to take advantage of INFI-NET/ Superloop capabilities.
5	1	1	0	1	0	0	0	0	Permit segment modification (allows change to segment scheme configured with function code 82, specification S1).
6	1	0	1	1	0	0	0	0	Enable time-stamping. This operation instructs the MFC to generate time information with point data. It is applicable only to INFI-NET/ Superloop systems.

NOTE: 0 = CLOSED or ON, 1 = OPEN or OFF.

Table A-3. IMMFC03 Dipswitch U73 Baud Rate Settings

Baud Rate	Switch Position								Baud Rate	Switch Position							
	Terminal Port 1				Printer Port 2					Terminal Port 1				Printer Port 2			
	1	2	3	4	5	6	7	8		1	2	3	4	5	6	7	8
50.0	0	0	0	0	0	0	0	0	1800.0	0	0	0	1	0	0	0	1
75.0	1	0	0	0	1	0	0	0	2000.0	1	0	0	1	1	0	0	1
110.0	0	1	0	0	0	1	0	0	2400.0	0	1	0	1	0	1	0	1
134.5	1	1	0	0	1	1	0	0	3600.0	1	1	0	1	1	1	0	1
150.0	0	0	1	0	0	0	1	0	4800.0	0	0	1	1	0	0	1	1
300.0	1	0	1	0	1	0	1	0	7200.0	1	0	1	1	1	0	1	1
600.0	0	1	1	0	0	1	1	0	9600.0	0	1	1	1	0	1	1	1
1200.0	1	1	1	0	1	1	1	0	19200.0	1	1	1	1	1	1	1	1

NOTE: 0 = CLOSED or ON, 1 = OPEN or OFF.

Table A-4. Example IMMFC03 Dipswitch U75 Module Address Settings

Address Example	Dipswitch Position (Binary Value)				
	1 (16)	2 (8)	3 (4)	4 (2)	5 (1)
7	0	0	1	1	1
15	0	1	1	1	1
31	1	1	1	1	1

NOTE: 0 = CLOSED or ON, 1 = OPEN or OFF.

# APPENDIX B - IMMFC04 MULTI-FUNCTION CONTROLLER

## INTRODUCTION

Several dipswitches must be set for the IMMFC04 Multi-Function Controller. Figure B-1 shows the IMMFC04 module layout. Tables B-1, B-2, and B-3 explain the dipswitch settings for the board. For more information on the module, refer to the **IMMFC04 Multi-Function Controller Module** product instruction.

**NOTE:** Jumpers J17 through J22 are factory set (jumper pins one and two) and should not be changed. Jumpers J23 and J24 are reserved for future use. The positions of J23 and J24 do not affect module operation.

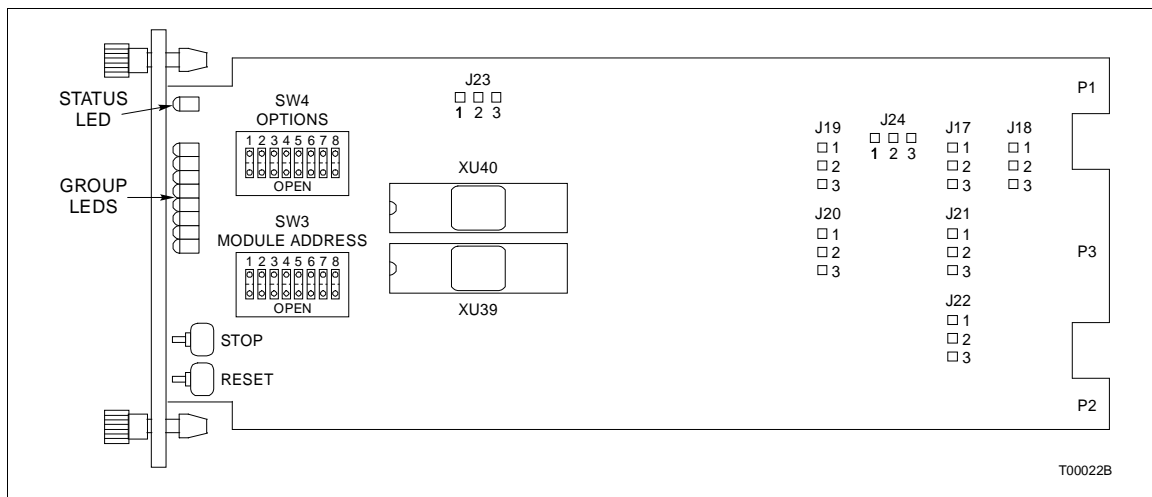

Figure B-1. IMMFC04 Module Layout

Table B-1. Example IMMFC04 Dipswitch SW3 Module Address Settings

Special Operation	Dipswitch Position (Binary Value)							
	1 <sup>1</sup> (128)	2 <sup>2</sup> (64)	3 <sup>3</sup> (32)	4 (16)	5 (8)	6 (4)	7 (2)	8 (1)
7	1	Y	X	0	0	1	1	1
15	1	Y	X	0	1	1	1	1
31	1	Y	X	1	1	1	1	1

**NOTES:** 0 = CLOSED or ON, 1 = OPEN or OFF.  
 1. Position 1 must be set open for proper operation.  
 2. Y = 0 for normal execution mode, 1 for diagnostic mode.  
 3. X = Not important.+



Table B-2. IMMFC04 Dipswitch SW4 Options Settings

Position	Setting	Function
1	0	Normal operation.
	1	Enable special operations (refer to Table B-3).
2	0	Disable on-line configuration.
	1	Enable on-line configuration.
3	0	Not used.
4	0	Perform ROM checksum routine.
	1	Inhibit ROM checksum routine.
5	0	Perform ROM check.
	1	Inhibit ROM check.
6	0	Normal operation.
	1	Compact configuration - moves configured blocks to the top of NVRAM while moving free space to the bottom (this is known as compacting). Leave switch OPEN and insert module into MMU. When front panel LEDs 1, 2 and 4 are ON, remove the module, put the switch in the CLOSED position and insert the module. The MFC goes into the configure mode and compacts the configuration.
7	0	Normal operation.
	1	Initialize NVRAM (erase configuration) - leave switch OPEN and insert the module into the MMU. When front panel LEDs 1, 2 and 4 are ON, remove the module, put the switch in the CLOSED position and insert the module. The module is now ready to be configured. This switch must be CLOSED for normal operation.
8	0	Primary MFC module.
	1	Redundant MFC module.

NOTE: 0 = CLOSED or ON, 1 = OPEN or OFF.+

Table B-3. IMMFC04 Dipswitch SW4 Special Operations Settings

Special Operation	Dipswitch Position								Description
	1	2	3	4	5	6	7	8	
0	0	0	0	0	0	0	0	0	Force module to configure mode.
1	1	0	0	0	0	0	0	1	Reserved for future use. If you use this setting, your module may not operate properly.
2	1	0	0	0	0	0	1	0	Initialize NVRAM configuration space.
3	1	0	0	0	0	0	1	1	Reserved. Do not use. If you use this setting, your module may not operate properly.
4	1	0	0	0	0	1	0	0	INFI-NET protocol enable. This allows the MFC module to take advantage of INFI-NET/Superloop capabilities.
5	1	1	0	1	0	0	0	0	Permit segment modification (allows change to segment scheme configured with function code 82, specification S1).
6	1	0	1	1	0	0	0	0	Enable time-stamping. This operation instructs the MFC to generate time information with point data. It is applicable only to INFI-NET/Superloop systems.

NOTE: 0 = CLOSED or ON, 1 = OPEN or OFF.+

# APPENDIX C - IMMFC05 MULTI-FUNCTION CONTROLLER

## INTRODUCTION

Several dipswitches must be set for the IMMFC05 Multi-Function Controller. Figure C-1 shows the IMMFC05 module layout. Tables C-1, C-2, and C-3 explain the dipswitch settings for the board. For more information on the module, refer to the **IMMFC05 Multi-Function Controller Module** product instruction.

**NOTE:** Jumpers J17 through J22 are factory set (jumper pins one and two) and should not be changed. Jumpers J23 and J24 are reserved for future use. The positions of J23 and J24 do not affect module operation.

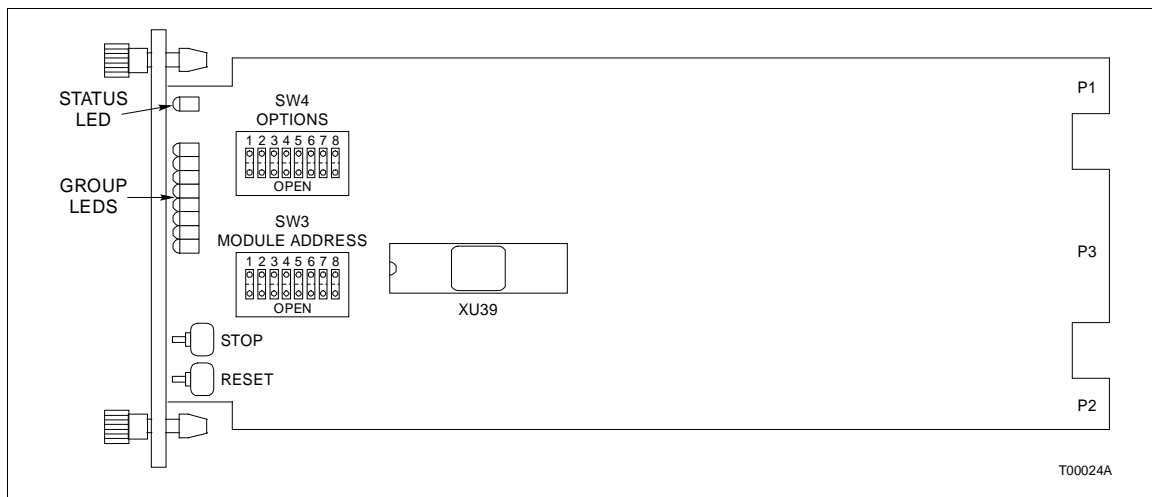

Figure C-1. IMMFC05 Module Layout

Table C-1. Example IMMFC05 Dipswitch SW3 Module Address Settings

Address Example	Dipswitch Position (Binary Value)							
	1 <sup>1</sup> (128)	2 <sup>2</sup> (64)	3 <sup>3</sup> (32)	4 (16)	5 (8)	6 (4)	7 (2)	8 (1)
7	1	Y	X	0	0	1	1	1
15	1	Y	X	0	1	1	1	1
31	1	Y	X	1	1	1	1	1

**NOTES:** 0 = CLOSED or ON, 1 = OPEN or OFF.  
 1. Position 1 must be set open for proper operation.  
 2. Y = 0 for normal execution mode, 1 for diagnostic mode.  
 3. X = Not important.

Table C-2. IMMFC05 Dipswitch SW4 Option Settings

Position	Setting	Function
1	0	Normal operation.
	1	Enable special operations (refer to Table C-3).
2	0	Disable on-line configuration.
	1	Enable on-line configuration.
3	0	Not used.
4	0	Perform ROM checksum routine.
	1	Inhibit ROM checksum routine.
5	0	Perform ROM check.
	1	Inhibit ROM check.
6	0	Normal operation.
	1	Compact configuration - moves configured blocks to the top of NVRAM while moving free space to the bottom (this is known as compacting). Leave switch OPEN and insert module into MMU. When front panel LEDs 1, 2 and 4 are ON, remove the module, put the switch in the CLOSED position and insert the module. The MFC goes into the configure mode and compacts the configuration.
7	0	Normal operation.
	1	Initialize NVRAM (erase configuration) - leave switch OPEN and insert the module into the MMU. When front panel LEDs 1, 2 and 4 are ON, remove the module, put the switch in the CLOSED position and insert the module. The module is now ready to be configured. This switch must be CLOSED for normal operation.
8	0	Primary MFC module.
	1	Redundant MFC module.

NOTE: 0 = CLOSED or ON, 1 = OPEN or OFF.+

Table C-3. IMMFC05 Dipswitch SW4 Special Operation Settings

Special Operation	Dipswitch Position								Description
	1	2	3	4	5	6	7	8	
0	0	0	0	0	0	0	0	0	Force module to configure mode.
1	1	0	0	0	0	0	0	1	Reserved for future use. If you use this setting, your module may not operate properly.
2	1	0	0	0	0	0	1	0	Initialize NVRAM configuration space.
3	1	0	0	0	0	0	1	1	Reserved. Do not use. If you use this setting, your module may not operate properly.
4	1	0	0	0	0	1	0	0	INFI-NET protocol enable. This allows the MFC module to take advantage of INFI-NET/Superloop capabilities.
5	1	1	0	1	0	0	0	0	Permit segment modification (allows change to segment scheme configured with function code 82, specification S1).
6	1	0	1	1	0	0	0	0	Enable time-stamping. This operation instructs the MFC to generate time information with point data. It is applicable only to INFI-NET/Superloop systems.

NOTE: 0 = CLOSED or ON, 1 = OPEN or OFF.

# APPENDIX D - INPPT01 PLANT LOOP TO PLANT LOOP TRANSFER MODULE

## INTRODUCTION

Several dipswitches must be set for the INPPT01 Plant Loop to Plant Loop Transfer Module. The INPPT01 module consists of two circuit boards: a memory board and a CPU board. The memory board has no user configurable operating options. The CPU board has three dipswitches that set the module operating characteristics. Figure D-1 shows the CPU board layout. Tables D-1, D-2, and D-3 explain the dipswitch settings for the CPU board. For more information on the module, refer to the **INPPR01 Plant Loop to Plant Loop Remote Interface** product instruction.

**NOTE:** Jumpers J1 through J3 are factory set. Do not change the jumper settings.

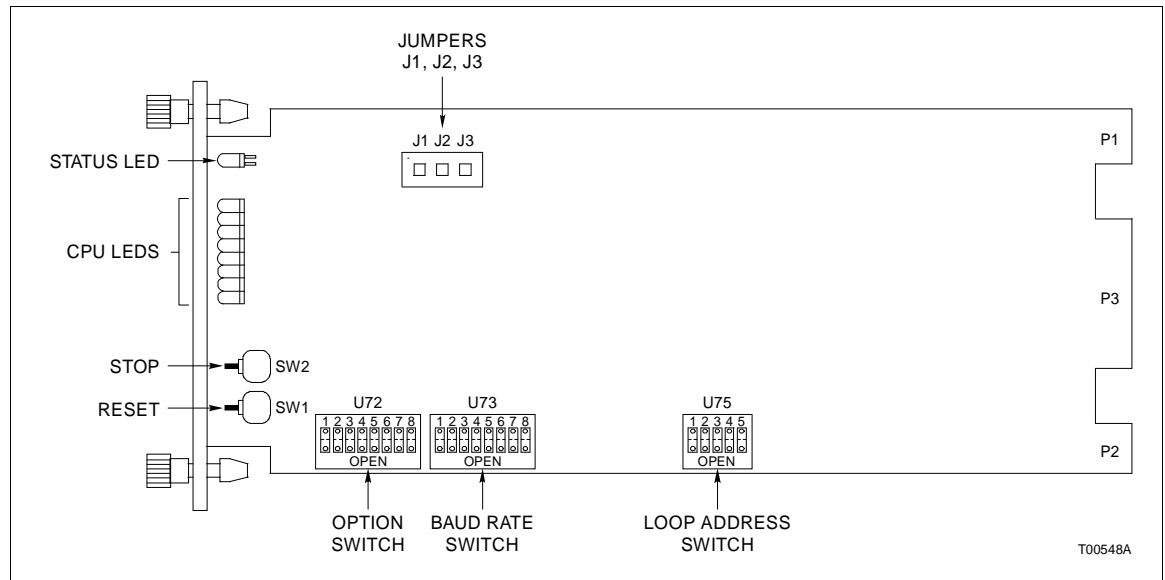

Figure D-1. INPPT01 CPU Board Layout

Table D-1. INPPT01 Dipswitch U72 Option Switch Settings

Position	Setting	Function
1	0	ROM checksumming enabled.
	1	ROM checksumming disabled.
2	0	RS-232-C port in DCE mode (direct connections).
	1	RS-232-C port in DTE mode (modem connections).
3	0	Equipment select output de-energized.
	1	Equipment select output energized. A unique equipment select output can exist between the primary and secondary PPT module. The equipment select output is digital output 3 of a digital slave (IMDSM05 or IMDSO01/02/03/04 module).

Table D-1. INPPT01 Dipswitch U72 Option Switch Settings (continued)

Position	Setting	Function
4	0	Port 2 option interface communication.
	1	Port 2 utility option. Port 2 responds as DCE when it is configured as a utility port. Set switch position 4 = 1 if port 2 is not used as a communication interface.
5	0	Interface ID local. Define only one interface as a local interface.
	1	Interface ID remote.
6	0	Interface mode two-way control. The following conditions apply: 1. The port 2 option defaults to interface communication (position 4 = 0). 2. The local INPPR01 interface uses port 1 as its command port and port 2 as its reply port. 3. The remote INPPR01 interface uses port 2 as its command port and port 1 as its reply port. 4. Both the local and remote interface must have a loop address of 0 (U75).
	1	Interface mode one-way control.
7	0	Do not initialize NVRAM.
	1	Initialize NVRAM.
8	0	Primary module.
	1	Redundant module.

NOTE: 0 = CLOSED or ON, 1 = OPEN or OFF.

Table D-2. INPPT01 Dipswitch U73 Baud Rate Settings

Baud Rate	Switch Position								Baud Rate	Switch Position							
	Terminal Port 1				Printer Port 2					Terminal Port 1				Printer Port 2			
	1	2	3	4	5	6	7	8		1	2	3	4	5	6	7	8
50.0	0	0	0	0	0	0	0	0	1800.0	0	0	0	1	0	0	0	1
75.0	1	0	0	0	1	0	0	0	2000.0	1	0	0	1	1	0	0	1
110.0	0	1	0	0	0	1	0	0	2400.0	0	1	0	1	0	1	0	1
134.5	1	1	0	0	1	1	0	0	3600.0	1	1	0	1	1	1	0	1
150.0	0	0	1	0	0	0	1	0	4800.0	0	0	1	1	0	0	1	1
300.0	1	0	1	0	1	0	1	0	7200.0	1	0	1	1	1	0	1	1
600.0	0	1	1	0	0	1	1	0	9600.0	0	1	1	1	0	1	1	1
1200.0	1	1	1	0	1	1	1	0	19200.0	1	1	1	1	1	1	1	1

NOTE: 0 = CLOSED or ON, 1 = OPEN or OFF.

*Table D-3. Example INPPT01 Dipswitch U75 Loop Address Settings*

<b>Address Example</b>	<b>Dipswitch Position (Binary Value)</b>				
	<b>1 (16)</b>	<b>2 (8)</b>	<b>3 (4)</b>	<b>4 (2)</b>	<b>5 (1)</b>
7	0	0	1	1	1
15	0	1	1	1	1
31	1	1	1	1	1

**NOTE:** 0 = CLOSED or ON, 1 = OPEN or OFF..

# APPENDIX E - INPCT01 PLANT LOOP TO COMPUTER TRANSFER MODULE

## INTRODUCTION

Several dipswitches must be set for the INPCT01 Plant Loop to Computer Transfer Module. The INPCT01 module consists of two circuit boards: a memory board and a CPU board. The memory board has no user configurable operating options. The CPU board has three dipswitches that set the module operating characteristics. Figure E-1 shows the CPU board layout. Tables E-1, E-2, and E-3 explain the dipswitch settings for the CPU board. For more information on the module, refer to the **INPCI02 Plant Loop to Computer Interface** product instruction.

**NOTE:** Jumpers J1 through J3 are factory set. Do not change the jumper settings.

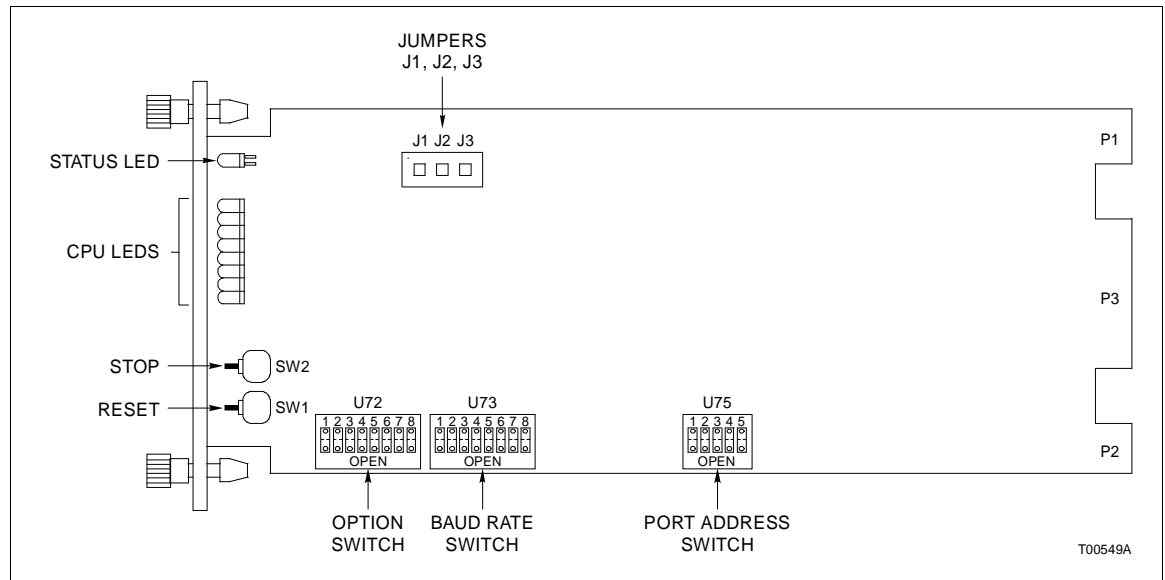

Figure E-1. INPCT01 CPU Board Layout

Table E-1. INPCT01 Dipswitch U72 Option Settings

Position	Setting	Function
1	0	ROM checksumming enabled.
	1	ROM checksumming disabled.
2/3		Ports 1 and 2 data characteristics.
	0/0	8 data bits, 1 stop bit, no parity.
	0/1	8 data bits, 1 stop bit, even parity.
2/3 (cont.)	1/0	8 data bits, 1 stop bit, odd parity.
	1/1	8 data bits, 2 stop bits, no parity.

Table E-1. .INPCT01 Dipswitch U72 Option Settings (continued)

Position	Setting	Function
4	0	Port 2 option serial port to host.
	1	Port 2 utility option. If this option is selected, port 1 data characteristics are automatically set to 8 data bits, 1 stop bit, no parity. Otherwise, port 2 data characteristics are set by dipswitch positions 2 and 3.
5	0	Modem password protection disabled.
	1	Modem password protection enabled.
6	0	Port addressing mode disabled.
	1	Port addressing mode enabled. When this option is enabled, the PCT module will expect all commands from the host to send the port address selected on the dipswitch U75 as the first character of each command.
7	0	Checksumming option disabled.
	1	Checksumming option enabled. When this option is enabled, the PCT module will expect all commands from the host to include a checksum byte as the last character before the carriage return. The PCT module includes a checksum in each reply.
8	N/A	This dipswitch position is undefined.

NOTE: 0 = CLOSED or ON, 1 = OPEN or OFF.

Table E-2. INPCT01 Dipswitch U73 Baud Rate Settings

Baud Rate	Switch Position								Baud Rate	Switch Position							
	Terminal Port 1				Printer Port 2					Terminal Port 1				Printer Port 2			
	1	2	3	4	5	6	7	8		1	2	3	4	5	6	7	8
50.0	0	0	0	0	0	0	0	0	1800.0	0	0	0	1	0	0	0	1
75.0	1	0	0	0	1	0	0	0	2000.0	1	0	0	1	1	0	0	1
110.0	0	1	0	0	0	1	0	0	2400.0	0	1	0	1	0	1	0	1
134.5	1	1	0	0	1	1	0	0	3600.0	1	1	0	1	1	1	0	1
150.0	0	0	1	0	0	0	1	0	4800.0	0	0	1	1	0	0	1	1
300.0	1	0	1	0	1	0	1	0	7200.0	1	0	1	1	1	0	1	1
600.0	0	1	1	0	0	1	1	0	9600.0	0	1	1	1	0	1	1	1
1200.0	1	1	1	0	1	1	1	0	19200.0	1	1	1	1	1	1	1	1

NOTE: 0 = CLOSED or ON, 1 = OPEN or OFF.



Table E-3. Example INPPT01 Dipswitch U75 Loop Address Settings

Address Example	Dipswitch Position (Binary Value)				
	1 (16)	2 (8)	3 (4)	4 (2)	5 (1)
7	0	0	1	1	1
15	0	1	1	1	1
31	1	1	1	1	1

NOTE: 0 = CLOSED or ON, 1 = OPEN or OFF.+

# APPENDIX F - INICT01 INFI-NET TO COMPUTER TRANSFER MODULE

## INTRODUCTION

Several dipswitches must be set for the INICT01 INFI-NET to Computer Transfer Module. The INICT01 module consists of two circuit boards: a memory board and a CPU board. The memory board has no user configurable operating options. The CPU board has three dipswitches that set the module operating characteristics. Figure F-1 shows the CPU board layout. Tables F-1, F-2, and F-3 explain the dipswitch settings for the CPU board. For more information on the module, refer to the **INFI-NET Communication Modules** product instruction.

**NOTE:** Jumpers J1 through J3 are factory set. Do not change the jumper settings.

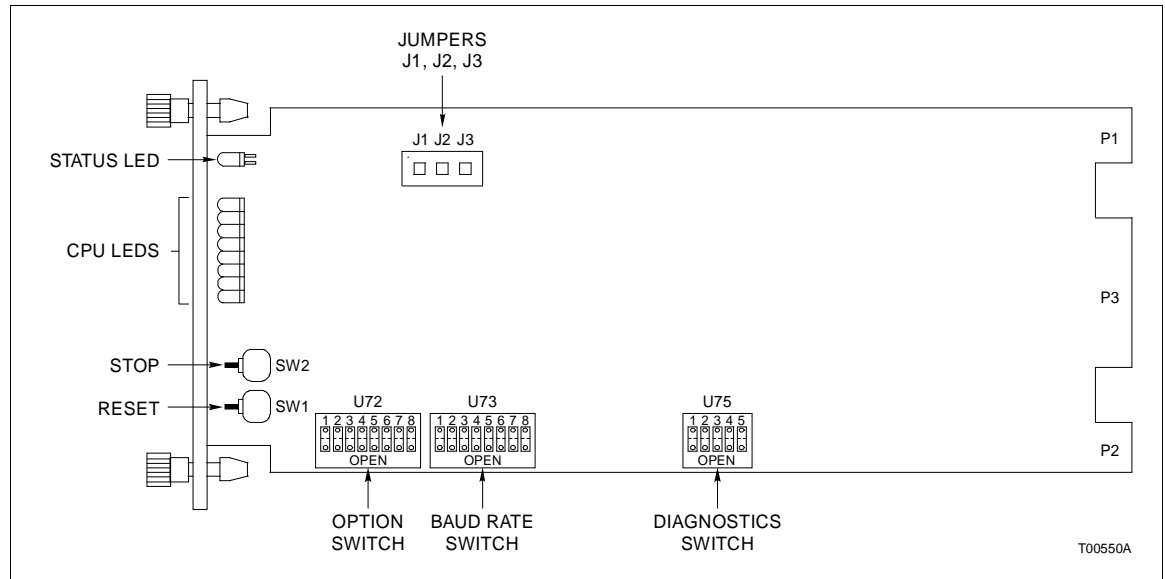

Figure F-1. INICT01 CPU Board Layout

Table F-1. INICT01 Dipswitch U72 Option Settings

Position	Setting	Function
1	0	ROM checksumming enabled.
	1	ROM checksumming disabled.
2/3		Ports 1 and 2 data characteristics.
	0/0	8 data bits, 1 stop bit, no parity.
	0/1	8 data bits, 1 stop bit, even parity.
2/3 (cont.)	1/0	8 data bits, 1 stop bit, odd parity.
	1/1	8 data bits, 2 stop bits, no parity.

Table F-1. INICT01 Dipswitch U72 Option Settings (continued)

Position	Setting	Function
4	0	Port 2 option serial port to host.
	1	Port 2 utility option. If this option is selected, port 2 data characteristics are automatically set to 8 data bits, 1 stop bit, no parity. Otherwise, port 2 data characteristics are set by dipswitch positions 2 and 3.
5	0	Modem password protection disabled.
	1	Modem password protection enabled.
6	0	Port addressing mode disabled.
	1	Port addressing mode enabled. When this option is enabled, the ICT module will expect all commands from the host to send the port address configured through the UTILITIES as the first character of each command.
7	0	Checksumming option disabled.
	1	Checksumming option enabled. When this option is enabled, the ICT module will expect all commands from the host to include a checksum byte as the last character before the carriage return. The ICT module includes a checksum in each reply.
8	N/A	Not used.

NOTE: 0 = CLOSED or ON, 1 = OPEN or OFF.

Table F-2. INPPT01 Dipswitch U73 Baud Rate Settings

Baud Rate	Switch Position								Baud Rate	Switch Position							
	Terminal Port 1				Printer Port 2					Terminal Port 1				Printer Port 2			
	1	2	3	4	5	6	7	8		1	2	3	4	5	6	7	8
50.0	0	0	0	0	0	0	0	0	1800.0	0	0	0	1	0	0	0	1
75.0	1	0	0	0	1	0	0	0	2000.0	1	0	0	1	1	0	0	1
110.0	0	1	0	0	0	1	0	0	2400.0	0	1	0	1	0	1	0	1
134.5	1	1	0	0	1	1	0	0	3600.0	1	1	0	1	1	1	0	1
150.0	0	0	1	0	0	0	1	0	4800.0	0	0	1	1	0	0	1	1
300.0	1	0	1	0	1	0	1	0	7200.0	1	0	1	1	1	0	1	1
600.0	0	1	1	0	0	1	1	0	9600.0	0	1	1	1	0	1	1	1
1200.0	1	1	1	0	1	1	1	0	19200.0	1	1	1	1	1	1	1	1

NOTE: 0 = CLOSED or ON, 1 = OPEN or OFF.

*Table F-3. INICT01 Dipswitch U75 Diagnostics Settings*

<b>Position</b>	<b>Setting</b>	<b>Function</b>
1	0	NIS handshake time-out enabled.
	1	NIS handshake time-out disabled.
2	0	NIS diagnostic disabled.
	1	NIS diagnostic enabled.
3	0	INFI-NET diagnostic utilities disabled.
	1	INFI-NET diagnostic utilities enabled.
4/5	0	Not used.

**NOTE:**0 = CLOSED or ON, 1 = OPEN or OFF.

# Index

<b>A</b>	
Application	
Hardware .....	1-4
Plant Loop to computer.....	1-2
Plant Loop to Plant Loop .....	1-3
Redundant module .....	1-1
Assignments	
DB-25 pin .....	2-15
Terminal	
NIMF01 .....	2-16
NIMF02 .....	2-16
<b>C</b>	
Cable	
Applications .....	2-12
Connections.....	2-5
NIMF01 .....	2-14
NIMF02 .....	2-15
Installation.....	2-6
NKTU01 .....	2-7
NKTU02 .....	2-7
NKTU12 .....	2-7
Ribbon.....	2-10
RS-232-C .....	2-9
Length.....	2-12
Connector assignments	
NIMF01 .....	2-3
NIMF02 .....	2-4
<b>D</b>	
Dipshunt configuration	
DCE .....	2-3
Diagnostic terminal .....	2-12
ICT Module .....	2-7
Direct connection of local PPT module.....	2-10
Direct connection of remote PPT module.....	2-11
Direct connection to host computer .....	2-5
Direct connection to mainframe computer .....	2-8
Direct connection to modem .....	2-6
DTE.....	2-3
INPPT01 module .....	2-4
Mainframe computer.....	2-3
PPT Module Acting as DTE .....	2-9
Dipshunt locations	
NIMF01 .....	2-3
NIMF02 .....	2-4
Dipswitch settings	
IMMFC03	
U72 .....	A-1
U73 .....	A-3
U75 .....	A-3
IMMFC04	
SW3.....	B-1
SW4.....	B-2
IMMFC05	
SW3.....	C-1
SW4.....	C-2
INICT01	
U72.....	F-2
U73.....	F-2
U75.....	F-3
INPCT01	
U72.....	E-1
INPPT01	
U72.....	D-1, D-3
U73.....	D-2
U75.....	D-3
<b>F</b>	
Features.....	1-3
<b>G</b>	
Glossary .....	1-4
<b>H</b>	
Hardware application .....	1-4
How to use this manual.....	1-4
<b>I</b>	
INICT01 INFI-NET to computer transfer module .....	F-1
INPCT01 Plant Loop to computer transfer module ....	E-1
INPPT01 Plant Loop to Plant Loop transfer module ..	D-1
Inspection.....	2-2
Installation.....	2-1
Physical.....	2-2
Setup.....	2-2
Termination module .....	2-11
Instruction content.....	1-4
Intended user .....	1-2
Introduction .....	1-1
<b>L</b>	
Layout	
IMMFC03 .....	A-1
IMMFC04 .....	B-1
IMMFC05 .....	C-1
INICT01 .....	F-1
INPCT01 .....	E-1

# Index (continued)

INPPT01.....	D-1	RS-232-C signals .....	2-15
<b>M</b>		<b>S</b>	
Maintenance .....	3-1	Sequence of events recorder .....	2-4
Schedule .....	3-1	Sequential events recorder .....	
Module description .....	1-3	ESA control SER-740 .....	2-13
Module replacement procedures.....	4-1	Rochester 3800 .....	2-13
Multi-function controller .....		Rochester ISM .....	2-13
IMMFC03.....	A-1	Special handling .....	2-1
IMMFC04.....	B-1	Specifications .....	1-6
IMMFC05.....	C-1	Support services .....	5-1
<b>N</b>		<b>T</b>	
Nomenclature.....	1-6	Technical documentation.....	5-1
<b>O</b>		Terminal wiring .....	2-12
Overview .....	1-1	Training.....	5-1
<b>R</b>		<b>U</b>	
Recommended spare parts list .....	4-1	Unpacking.....	2-2
Reference documents .....	1-5	<b>W</b>	
Repair/replacement procedures.....	4-1	Wiring .....	2-12
Replacement parts and ordering information .....	5-1		

Visit *Elsag Bailey* on the World Wide Web at <http://www.bailey.com>

---

Our worldwide staff of professionals is ready to meet *your* needs for process automation.  
For the location nearest you, please contact the appropriate regional office.

**AMERICAS**

29801 Euclid Avenue  
Wickliffe, Ohio USA 44092  
Telephone 1-216-585-8500  
Telefax 1-216-585-8756

**ASIA/PACIFIC**

152 Beach Road  
Gateway East #20-04  
Singapore 189721  
Telephone 65-391-0800  
Telefax 65-292-9011

**EUROPE, AFRICA, MIDDLE EAST**

Via Puccini 2  
16154 Genoa, Italy  
Telephone 39-10-6582-943  
Telefax 39-10-6582-941

**GERMANY**

Graefstrasse 97  
D-60487 Frankfurt Main  
Germany  
Telephone 49-69-799-0  
Telefax 49-69-799-2406